

**Wide Operating
Temperature**

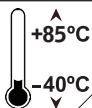

EmETXe-i90M0

COM Express® Basic Type 6 CPU Module Quick Installation Guide

Version 1.0

Form Factor <i>COM Express® Basic Type 6 CPU Module</i>	CPU <i>6th Generation Intel® Core™ i7-7820EQ/i5- 7442EQ</i>	Video <i>24-bit Dual Channels LVDS/ DDI</i>
LAN <i>Intel® i219LM PCIe GbE PHY with iAMT</i>	Audio <i>HD Audio Link</i>	I/O <i>USB / SATA/ PCIe / I2C/ GPIO / UART</i>

◆ Technical Support

If you have any technical difficulties, please consult the user's manual first on our website.

<http://www.arbor-technology.com>

Please do not hesitate to call or e-mail our customer service when you still can not find out the answer.

E-mail: info@arbor.com.tw

FCC Class A

This device complies with Part 15 of the FCC Rules. Operation is subject to the following two conditions : (1) this device may not cause harmful interference, and (2) this device must accept any interference received, including interference that may cause undesired operation.

Copyright® All Rights Reserved.



COM Express supports seven pin-out Type applying to Basic and Extended form factors:

Module Type 1 and 10 support single connector with two rows of pins (220 pins)

Module Type 2, 3, 4, 5 and 6 support two connectors with four rows of pins (440 pins) Connector placement and most mounting holes have transparency between Form Factors.

The differences among the Module Type 6 and EmETXe-i90M0 are summarized in table below:

Module Type	Standard Type 6	EmETXe-i90M0
Connectors	2	2
Connector Rows	A, B, C, D	A, B, C, D
PCIe Lanes (Max)	24	24
LAN (Max)	1	1
Serial Ports (Max)	2	2
Digital Display I/F (Max)	3	3
USB 3.0 Ports (Max)	4	4

Packing List

Before you begin installing your single board, please make sure that the following materials have been shipped:



1 x EmETXe-i90M0 COM Express CPU Module



1 x Driver CD

1 x Quick Installation Guide

If any of the above items is damaged or missing, contact your vendor immediately.

Specifications

System	
CPU	Soldered onboard 7 th Generation Intel® Core™ i7-7820EQ 3.7GHz/i5-7442EQ 2.9GHz processor
Chipset	Soldered onboard Intel QM175 PCH
Memory	2 x DDR4 SO-DIMM sockets
BIOS	AMI UEFI BIOS
Watchdog Timer	1~255 levels reset
I/O	
USB Port	12 x USB ports: - 8 x USB 2.0 ports - 4 x USB SuperSpeed ports
Serial Port	2 x UART ports (RX/TX only)
Expansion Bus	8 x PCIe1 lanes, 1 x PCIe16 lane, I2C Interface,GPIO
Storage	4 x Serial ATA ports with 600MB/s HDD transfer rate
Ethernet Chipset	1 x Intel® i219LM PCIe GbE PHY
Audio	HD audio link
TPM	Supports TPM (OEM Request)
Display	
Graphic Chipset	Integrated Intel® HD Graphics 630
Graphic Interface	LCD: Dual Channels 24-bit LVDS 3 x DDI ports
Mechanical & Environmental	
Power Requirement	8.5V~20V +/- 5% wide range voltage input, +5VSB
Power Consumption	4.12A@12V (i7-7820EQ Typical)
Operating Temp.	-40 ~ 85°C (-40 ~ 185°F)
Operating Humidity	10 ~ 95% @ 85°C (non-condensing)
Dimensions (L x W)	125 x 95 mm (4.9" x 3.7")

Ordering Information

EmETXe-i90M0-WT-7820EQ	7th Generation Intel® Core™ i7-7820EQ WT COM Express® Basic Type 6 CPU Module
EmETXe-i90M0-WT-7442EQ	7th Generation Intel® Core™ i5-7442EQ WT COM Express® Basic Type 6 CPU Module

Optional Accessories

HS-90M0-C1	Heat sink with Fan, with PAD(125x95x35mm)
HS-90M0-F2-T	Heat Spreader, with Threader, with PAD(95*95*11mm), only for i5-7442EQ Series
HS-90M0-F2-NT	Heat Spreader, through hole, with PAD(95*95*11mm), only for i5-7442EQ Series
PBE-1705-F1	COM Express® Type 6 evaluation carrier board with SIO F71869ED module in ATX form factor
CBK-03-1705-00	Cable kit 1 x SATA cable 2 x COM Flat cables

Find Device Drivers on CD

The CPU module supports Windows10. Find the necessary drivers on the CD that comes with your purchase.

Find the drivers on CD by the following paths:

Windows 10 64-bit

Driver	Path
Chipset	\\EmETXe-i90x0\Chipset
Graphic	\\EmETXe-i90x0\Graphic\win64
Audio	\\EmETXe-i90x0\Audio\Win10_Win8.1_Win8_Win7_WHQLx64
Ethernet	\\EmETXe-i90x0\Ethernet
ME	\\EmETXe-i90x0\ME
RST	\\EmETXe-i90x0\RST\SetupRST

Connectors Quick Reference

Top Side

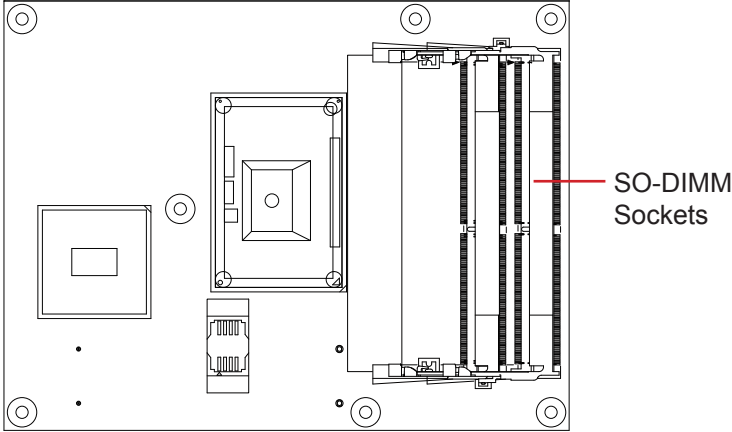

Bottom Side

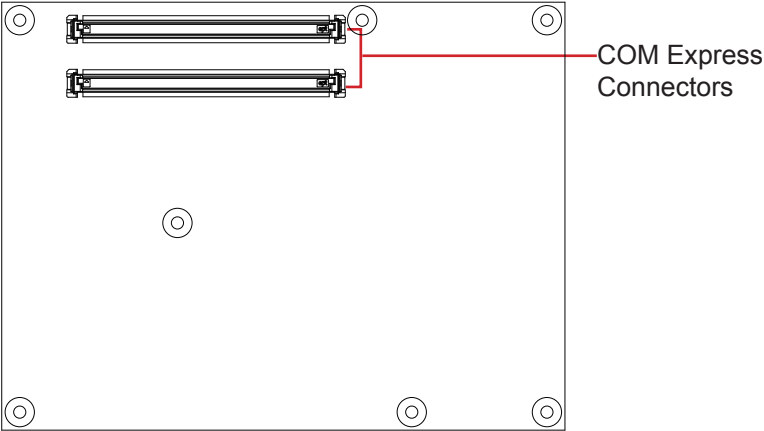

COM Express AB Connector (bottom side)

B1	GND (FIXED)	GND (FIXED)	A1	B56	PCIE_RX9-	PCIE_TX9-	A56
B2	GBE0_ACT#	GBE0_MDI3-	A2	B57	DIO_6	GND	A57
B3	LPC_FRAME#	GBE0_MDI3+	A3	B58	PCIE_RX4+	PCIE_TX4+	A58
B4	LPC_AD0	GBE0_LINK100#	A4	B59	PCIE_RX4-	PCIE_TX4-	A59
B5	LPC_AD1	GBE0_LINK1000#	A5	B60	GND	GND	A60
B6	LPC_AD2	GBE0_MDI2-	A6	B61	PCIE_RX3+	PCIE_TX3+	A61
B7	LPC_AD3	GBE0_MDI2+	A7	B62	PCIE_RX3-	PCIE_TX3-	A62
B8	LPC_DRQ0#	GBE0_LINK#	A8	B63	DIO_7	DIO_1	A63
B9	LPC_DRQ1#	GBE0_MDI1-	A9	B64	PCIE_RX2+	PCIE_TX2+	A64
B10	LPC_CLK	GBE0_MDI1+	A10	B65	PCIE_RX2-	PCIE_TX2-	A65
B11	GND (FIXED)	GND (FIXED)	A11	B66	PCH_WAKE#	GND	A66
B12	CB_PWRBTN#	GBE0_MDI0-	A12	B67	EC_WAKE_IN#	DIO_2	A67
B13	CB_SMB_CLK	GBE0_MDI0+	A13	B68	PCIE_RX1+	PCIE_TX1+	A68
B14	CB_SMB_DAT	GBE0_CTREF	A14	B69	PCIE_RX1-	PCIE_TX1-	A69
B15	CB_SMB_ALERT#	SLP_S3#	A15	B70	GND	GND	A70
B16	SATA1_TX+	SATA0_TX+	A16	B71	LVDSB_DATA0+	LVDSA_DATA0+	A71
B17	SATA1_TX-	SATA0_TX-	A17	B72	LVDSB_DATA0-	LVDSA_DATA0-	A72
B18	SUS_STAT#	SLP_S4#	A18	B73	LVDSB_DATA1+	LVDSA_DATA1+	A73
B19	SATA1_RX+	SATA0_RX+	A19	B74	LVDSB_DATA1-	LVDSA_DATA1-	A74
B20	SATA1_RX-	SATA0_RX-	A20	B75	LVDSB_DATA2+	LVDSA_DATA2+	A75
B21	GND (FIXED)	GND (FIXED)	A21	B76	LVDSB_DATA2-	LVDSA_DATA2-	A76
B22	SATA3_TX+	SATA2_TX+	A22	B77	LVDSB_DATA3+	LVDS_VDD_EN	A77
B23	SATA3_TX-	SATA2_TX-	A23	B78	LVDSB_DATA3-	LVDSA_DATA3+	A78
B24	CB_PWROK	SLP_S5#	A24	B79	LVDSBKLTEN	LVDSA_DATA3-	A79
B25	SATA3_RX+	SATA2_RX+	A25	B80	GND	GND	A80
B26	SATA3_RX-	SATA2_RX-	A26	B81	LVDSB_CLK+	LVDSA_CLK+	A81
B27	WDT	PM_BATLOW#	A27	B82	LVDSB_CLK-	LVDSA_CLK-	A82
B28	N/C	SATA_ACT#	A28	B83	COM_BKLT_CTRL	LVDS_CK_EDP_AUXP	A83
B29	HDA_SDIN1	HDA_SYNC	A29	B84	VCC_5V_SBY	LVDS_DAT_EDP_AUXN	A84
B30	HDA_SDINO	HDA_RST#	A30	B85	VCC_5V_SBY	DIO_3	A85
B31	GND	GND	A31	B86	VCC_5V_SBY	H_RCIN	A86
B32	SPKR	HDA_BITCLK	A32	B87	VCC_5V_SBY	COME_EDP_HPD	A87
B33	I2C_CK	HDA_SDOUT	A33	B88	BIOS_DISABLE1#	PCIE_CLK+	A88
B34	I2C_DAT	BIOS_DISABLE0#	A34	B89	N/C	PCIE_CLK-	A89
B35	THRM#	CB_TRIP#	A35	B90	GND	GND	A90
B36	USB7-	USB6-	A36	B91	N/C	SPL_POWER	A91
B37	USB7+	USB6+	A37	B92	N/C	SPL_MISO	A92
B38	USB_4_5_OC#	USB_6_7_OC#	A38	B93	N/C	DIO_4	A93
B39	USB5-	USB4-	A39	B94	N/C	SPL_CK	A94
B40	USB5+	USB4+	A40	B95	N/C	SPL_MOSI	A95
B41	GND	GND	A41	B96	N/C	COM_TPM_PP	A96
B42	USB3-	USB2-	A42	B97	SPL_CS1#	N/C	A97
B43	USB3+	USB2+	A43	B98	N/C	UART_TX0	A98
B44	USB_0_1_OC#	USB_2_3_OC#	A44	B99	N/C	UART_RX0	A99
B45	USB1-	USB0-	A45	B100	GND	GND	A100
B46	USB1+	USB0+	A46	B101	FAN_PWMOUT	UART_TX1	A101
B47	PLTRST#_BUFF	VTRC_BT#	A47	B102	FAN_TACHIN	UART_RX1	A102
B48	EXCD1_CPPE#	PLTRST#_BUFF	A48	B103	SLEEP#	LID#	A103
B49	SYS_RESET#	EXCD0_CPPE#	A49	B104	VCC_12V	VCC_12V	A104
B50	CB_RESET#	LPC_SERIRQ	A50	B105	VCC_12V	VCC_12V	A105
B51	GND	GND	A51	B106	VCC_12V	VCC_12V	A106
B52	PCIE_RX10+	PCIE_TX10+	A52	B107	VCC_12V	VCC_12V	A107
B53	PCIE_RX10-	PCIE_TX10-	A53	B108	VCC_12V	VCC_12V	A108
B54	DIO_5	DIO_0	A54	B109	VCC_12V	VCC_12V	A109
B55	PCIE_RX9+	PCIE_TX9+	A55	B110	GND	GND	A110

COM Express CD Connector (bottom side)

D1	GND (FIXED)	GND (FIXED)	C1	D56	PEG_TX1-	PEG_RX1-	C56
D2	GND	GND	C2	D57	TYPE2#	N/C	C57
D3	USB_SSTX0-	USB_SSRX0-	C3	D58	PEG_TX2+	PEG_RX2+	C58
D4	USB_SSTX0+	USB_SSRX0+	C4	D59	PEG_TX2-	PEG_RX2-	C59
D5	GND	GND	C5	D60	GND (FIXED)	GND (FIXED)	C60
D6	USB_SSTX1-	USB_SSRX1-	C6	D61	PEG_TX3+	PEG_RX3+	C61
D7	USB_SSTX1+	USB_SSRX1+	C7	D62	PEG_TX3-	PEG_RX3-	C62
D8	GND	GND	C8	D63	RSVD	RSVD	C63
D9	USB_SSTX2-	USB_SSRX2-	C9	D64	RSVD	RSVD	C64
D10	USB_SSTX2+	USB_SSRX2+	C10	D65	PEG_TX4+	PEG_RX4+	C65
D11	GND (FIXED)	GND (FIXED)	C11	D66	PEG_TX4-	PEG_RX4-	C66
D12	USB_SSTX3-	USB_SSRX3-	C12	D67	GND	RSVD	C67
D13	USB_SSTX3+	USB_SSRX3+	C13	D68	PEG_TX5+	PEG_RX5+	C68
D14	GND	GND	C14	D69	PEG_TX5-	PEG_RX5-	C69
D15	DDI1_CTRLCLK_AUX+	N/C	C15	D70	GND (FIXED)	GND (FIXED)	C70
D16	DDI1_CTRLCLK_AUX-	N/C	C16	D71	PEG_TX6+	PEG_RX6+	C71
D17	RSVD	RSVD	C17	D72	PEG_TX6-	PEG_RX6-	C72
D18	RSVD	RSVD	C18	D73	GND	GND	C73
D19	PCIE_TX6+	PCIE_RX6+	C19	D74	PEG_TX7+	PEG_RX7+	C74
D20	PCIE_TX6-	PCIE_RX6-	C20	D75	PEG_TX7-	PEG_RX7-	C75
D21	GND(FIXED)	GND(FIXED)	C21	D76	GND	GND	C76
D22	PCIE_TX7+	PCIE_RX7+	C22	D77	RSVD	RSVD	C77
D23	PCIE_TX7-	PCIE_RX7-	C23	D78	PEG_TX8+	PEG_RX8+	C78
D24	RSVD	DDI1_HPD	C24	D79	PEG_TX8-	PEG_RX8-	C79
D25	RSVD	N/C	C25	D80	GND (FIXED)	GND (FIXED)	C80
D26	DDI1_PAIR0+	N/C	C26	D81	PEG_TX9+	PEG_RX9+	C81
D27	DDI1_PAIR0-	RSVD	C27	D82	PEG_TX9-	PEG_RX9-	C82
D28	RSVD	RSVD	C28	D83	RSVD	RSVD	C83
D29	DDI1_PAIR1+	N/C	C29	D84	GND	GND	C84
D30	DDI1_PAIR1-	N/C	C30	D85	PEG_TX10+	PEG_RX10+	C85
D31	GND(FIXED)	GND (FIXED)	C31	D86	PEG_TX10-	PEG_RX10-	C86
D32	DDI1_PAIR2+	DDI2_CTRLCLK_AUX+	C32	D87	GND	GND	C87
D33	DDI1_PAIR2-	DDI2_CTRLDATA_AUX-	C33	D88	PEG_TX11+	PEG_RX11+	C88
D34	DDI1_DDC_AUX_SEL	DDI2_DDC_AUX_SEL	C34	D89	PEG_TX11-	PEG_RX11-	C89
D35	RSVD	RSVD	C35	D90	GND (FIXED)	GND (FIXED)	C90
D36	DDI1_PAIR3+	DDI3_CTRLCLK_AUX+	C36	D91	PEG_TX12+	PEG_RX12+	C91
D37	DDI1_PAIR3-	DDI3_CTRLDATA_AUX-	C37	D92	PEG_TX12-	PEG_RX12-	C92
D38	RSVD	DDI3_DDC_AUX_SEL	C38	D93	GND	GND	C93
D39	DDI2_PAIR0+	DDI3_PAIR0+	C39	D94	PEG_TX13+	PEG_RX13+	C94
D40	DDI2_PAIR0-	DDI3_PAIR0-	C40	D95	PEG_TX13-	PEG_RX13-	C95
D41	GND(FIXED)	GND(FIXED)	C41	D96	GND	GND	C96
D42	DDI2_PAIR1+	DDI3_PAIR1+	C42	D97	RSVD	RSVD	C97
D43	DDI2_PAIR1-	DDI3_PAIR1-	C43	D98	PEG_TX14+	PEG_RX14+	C98
D44	DDI2_HPD	DDI3_HPD	C44	D99	PEG_TX14-	PEG_RX14-	C99
D45	RSVD	RSVD	C45	D100	GND (FIXED)	GND (FIXED)	C100
D46	DDI2_PAIR2+	DDI3_PAIR2+	C46	D101	PEG_TX15+	PEG_RX15+	C101
D47	DDI2_PAIR2-	DDI3_PAIR2-	C47	D102	PEG_TX15-	PEG_RX15-	C102
D48	RSVD	RSVD	C48	D103	GND	GND	C103
D49	DDI2_PAIR3+	DDI3_PAIR3+	C49	D104	VCC_12V	VCC_12V	C104
D50	DDI2_PAIR3-	DDI3_PAIR3-	C50	D105	VCC_12V	VCC_12V	C105
D51	GND (FIXED)	GND (FIXED)	C51	D106	VCC_12V	VCC_12V	C106
D52	PEG_TX0+	PEG_RX0+	C52	D107	VCC_12V	VCC_12V	C107
D53	PEG_TX0-	PEG_RX0-	C53	D108	VCC_12V	VCC_12V	C108
D54	PEG_LANE_RV#	N/C	C54	D109	VCC_12V	VCC_12V	C109
D55	PEG_TX1+	PEG_RX1+	C55	D110	GND (FIXED)	GND (FIXED)	C110