

**Wide Operating
Temperature**

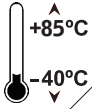

PBE-1705

COM Express Type 6 Evaluation Board

Quick Installation Guide

Version 1.1

Form Factor

**COM Express Type 6
Evaluation Board**

Video

**Dual Channels LVDS,
Analog RGB, DVI,
Display Port**

Audio

**Realtek HD Audio
CODEC, ALC886**

I/O

**PCI Express x16/x1/x4,
SATA, USB, COM, LPT,
Mini-card**

Ethernet

RJ-45 LAN Connector

◆ Technical Support

If you have any technical difficulties, please consult the user's manual first at:
<http://www.arbor-technology.com/>

Please do not hesitate to call or e-mail our customer service when you still can not find out the answer.

<http://www.arbor-technology.com/>

E-mail: info@arbor.com.tw

FCC Class A

This device complies with Part 15 of the FCC Rules. Operation is subject to the following two conditions : (1) this device may not cause harmful interference, and (2) this device must accept any interference received, including interference that may cause undesired operation.

Copyright© All Rights Reserved.



4041170500110P

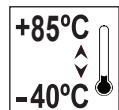

COM Express Module Type Summary Features

COM Express supports seven pin-out Type apply to Basic and Extended form factors: Module Type 1 and 10 supports single connector with two rows of pins (220 pins) Module Type 2, 3, 4, 5 and 6 support two connectors with four rows of pins (440 pins) Connector placement and most mounting holes have transparency between Form Factors.

The differences amount the Module Types are summarized in table below:

Module Type	1	10	2	3	4	5	6
Connectors	1	1	2	2	2	2	2
Connector Rows	A, B	A, B	A, B, C, D	A, B, C, D	A, B, C, D	A, B, C, D	A, B, C, D
PCIe Lanes (max)	6	4	22	22	32	32	24
PCI Bus	No	No	Yes	Yes	No	No	No
PATA - IDE	No	No	Yes	No	Yes	No	No
LAN (Max)	1	1	1	3	1	3	1
Serial Ports	No	0 / 2	No	No	No	No	0 / 2
Muxed SDVO	No	No	0 / 2	0 / 2	0 / 2	0 / 2	No
Digital Display I/F	No	No	No	No	No	No	0 / 3
USB 3.0 Ports	No	No	No	No	No	No	0 / 4

Packing List

Before you begin installing your single board, please make sure that the following materials have been shipped:

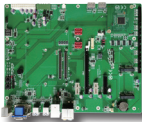

1 x PBE-1705 COM Express evaluation board



1 x Quick Installation Guide



1 x Super I/O Module

Specifications

Form Factor	COM Express evaluation board in ATX form factor
I/O Chips	Fintek F71869 (PBE-1705-F1)
Audio	Realtek HD Audio CODEC, ALC886
Serial ATA	4 x Serial ATA connectors (depending on CPU module)
Serial Port	Max. 6 x COM ports (depending on SIO module) Max. 2 x Ultra COM ports (depending on CPU module)
KB/MS	PS/2 keyboard/mouse connectors
USB	2 x USB 2.0 ports 4 x USB 3.0 ports (depending on CPU module)
Graphic Interface	Analog RGB/ DVI: 1 x Analog RGB connector, 1 x DVI connector LCD: 1 x LVDS connector DDI port: 2 x DisplayPort connectors
Digital I/O	8-bit Digital Input/Output (from CPU Module)
Expansion Interface	2 x PCIe1 slots 1 x PCIe4 slot 1 x PCIe16 slot 2 x Mini-card sockets
Power Requirement	DC 5V~20V or ATX Standard
Power Consumption	1.94A@12V, 0.17A@5V, 0.32A@3.3V with EmETXe-i89U0-6600U (Typical)
Operation Temp.	-40 ~ 85°C (-40 ~ 185°F)
Power Connector	ATX Connector / 4-pin Terminal Block Connector
Dimension (L x W)	305 x 243 mm (12" x 9.6")

Ordering Information

PBE-1705-F1	COM Express® Type 6 evaluation carrier board with Super IO F71869 module in ATX form factor
CBK-03-1705-00	Cable kit 2 x Serial port cables 1 x SATA cable

Board dimensions

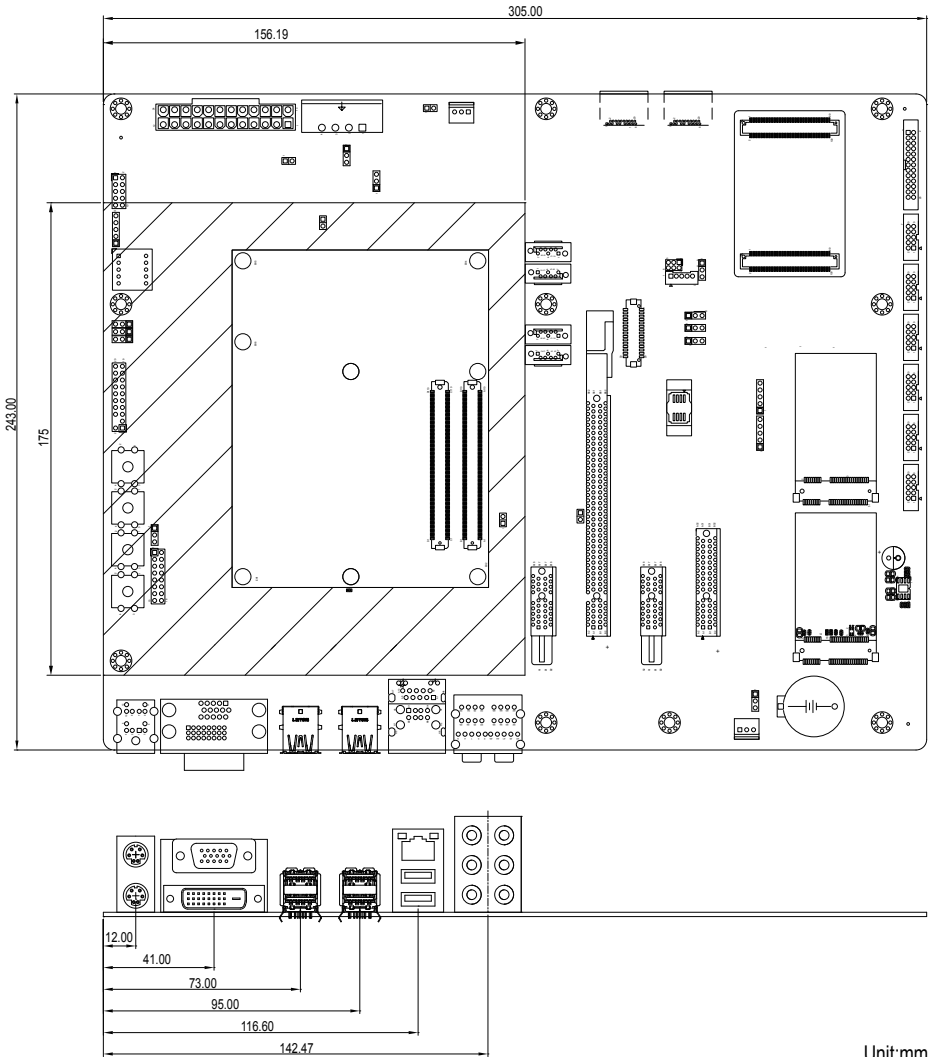

Unit:mm

SIO Module Installation

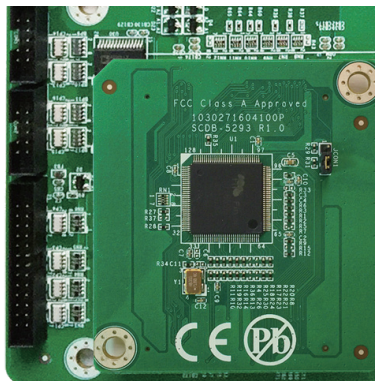
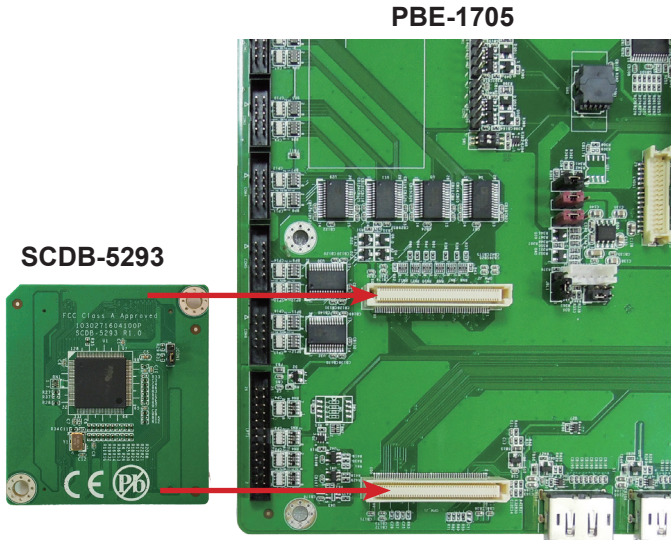

Jumpers/ Connectors Quick Reference

PBE-1705 Jumpers

Label	Description
JBAT1	Clear CMOS Selection
SW1	BIOS Boot Selection
JBLON1	LCD Backlight On Control Mode Selection
JVLCD1	LVDS Panel Voltage Selection
JINV1	LVDS1 Inverter Power Selection
JBL2	LVDS1 Brightness Control Level and Mode Selection
JVIN	DC IN Selection
JVDC	VDC Selection
JPSON1	ATX Power Supply Selection
J5VSB1	CPU Module 5VSB Power Selection
JPWOK1	Carrier Board Power OK Selection
JWDT1	Watchdog Source Selection
JAUDIO1	Audio Codec I/O Power Selection

SCDB-5293 Jumper

Label	Description
JCON1	Super I/O Address Selection

Connectors

Label	Function
KBM1	PS/2 Keyboard & Mouse Connector
VGA1	Analog RGB & DVI-D Display Connector
USB1~2	Double Stack USB Type A Connectors (support USB 3.0, depending on CPU module)
LAN1	RJ-45 & Double Stack USB Connector
AUDIO1	HD AUDIO Connector
PCIE1~2	PCIe×1 Slots
PCEG1	PCIe×16 Slot
PCIE3	PCIe×4 Slot
SYSP1	System Fan Power Connector
OPM_J1&2	SIO Module Connectors
MC1~2	PCI Express Mini-card Sockets
CON1~2	CPU Module Ultra Serial Ports (Only RX and TX)
COM1~6	RS-232 Serial Ports
LPT1	Parallel Port Connector
DP1~2	Displayport Connectors
CPUF1	CPU FAN Connector
PWRIN1	Power Input Terminal
ATX1	ATX Power Connector
DIO1	Digital I/O Connector
TPM1	Trusted Platform Module Connector (Optional)
JFRT1	Switches and Indicators Connector
LVDS1	LVDS Connector
SATA1~4	SATA Connectors
INV1	LCD Inverter Connector

Jumpers

PBE-1705

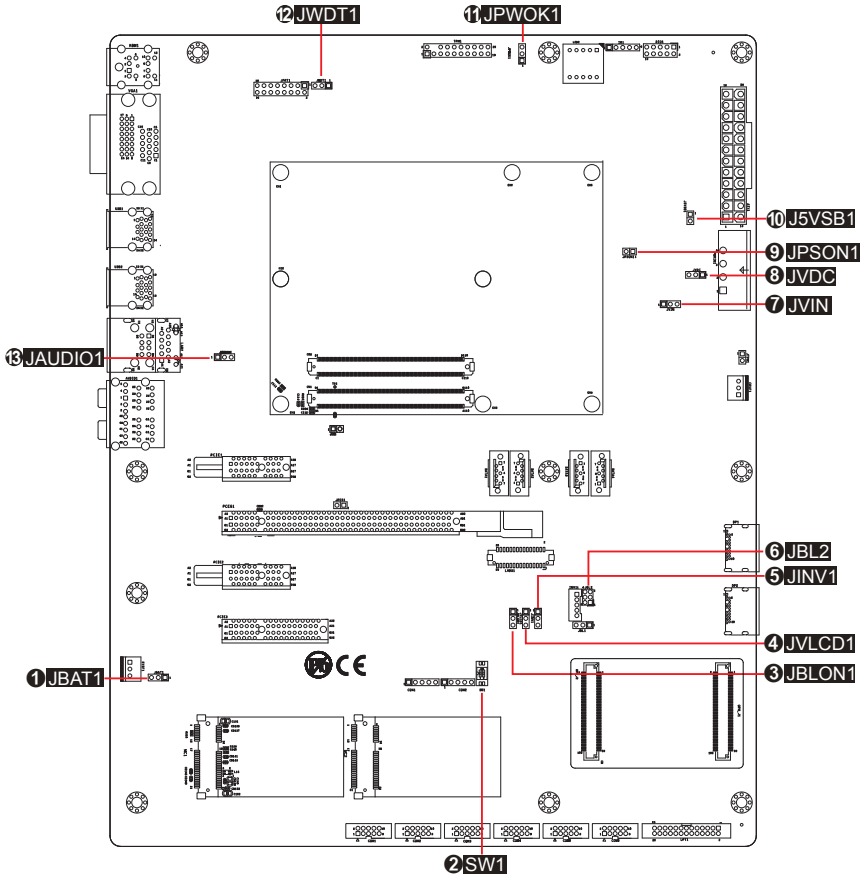

SCDB-5293

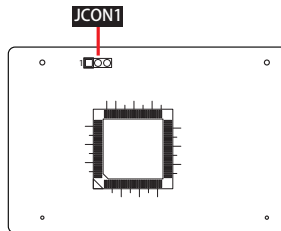

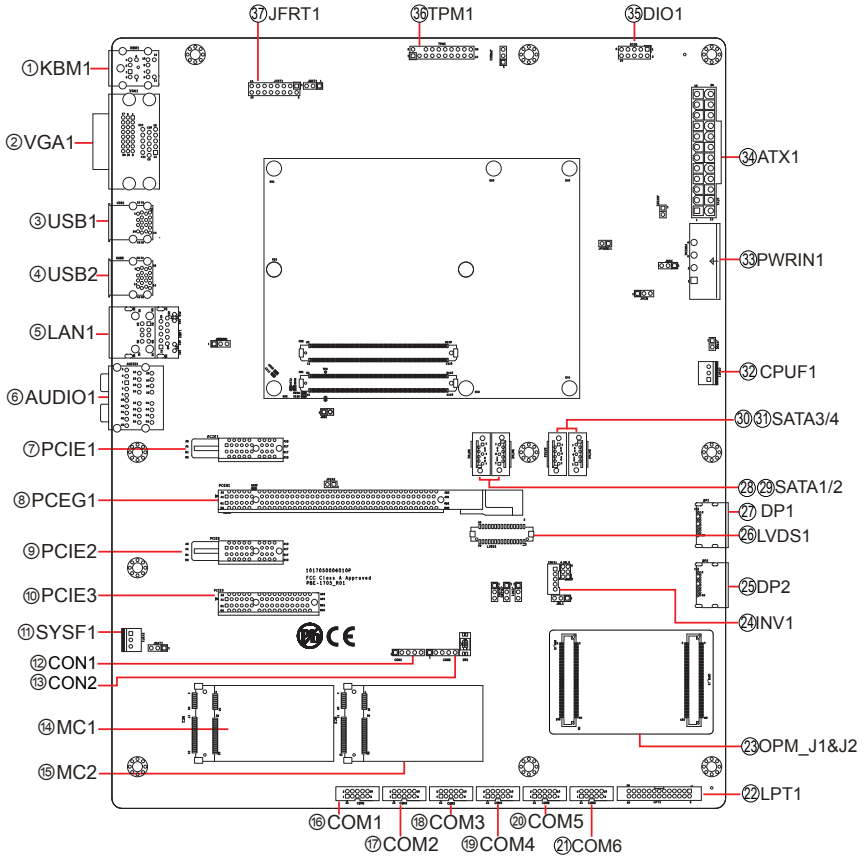

Connectors







PBE-1705

①JBAT1: Clear CMOS Selection

Connector type: 2.54mm pitch 1×3 pin header.

Pin	Mode	
1-2	Keep CMOS (default)	
2-3	Clear CMOS	

②SW1: BIOS Boot Selection

Function	1 2
Boot from CPU module SPI Flash	
Boot from CPU module SPI Flash	
Boot from Carrier Board SPI Flash	
Boot from CPU Module SPI Flash (Default)	

③JBLON1: LCD Backlight On Control Mode Selection



Connector type: 2.54mm pitch 1×3 pin header.

Pin	Mode	
1-2	0V low ON (Active Low)	
2-3	5V high ON (Active High) (default)	

④JVLCD1: LVDS Panel Voltage Selection

The voltage of LVDS panel could be selected by JVLCD1 in +5V or +3.3V.



Connector type: 2.54mm pitch 1×3 pin header.

Pin	Voltage	
1-2	+5V	
2-3	+3.3V (default)	

⑤JINV1: LCD Inverter Voltage Selection





The voltage of inverter could be selected by JINV1 in +5V or +12V.

Connector type: 2.54mm pitch 1×3 pin header.

Pin	Voltage	
1-2	+5V	
2-3	+12V (default)	

⑥JBL2: LVDS1 Brightness Control Level and Mode Selection



Connector type: 2.00mm pitch 2×3 pin header.

Pin	Brightness Control Source	
1-3	5V PWM mode control (default)	
3-5	3.3V PWM mode control	
2-4	5V DC level control	
4-6	0V DC level control	

⑦JVIN: DC IN Selection

The voltage of inverter could be selected by JINV in VDC or +12V.



Connector type: 2.54mm pitch 1×3 pin header.

Pin	Voltage	
1-2	VDC (5~20V)	
2-3	+12V (default)	

For **5~20V**, select **JVIN (1-2)** & **JVDC (2-3)**

⑧JVDC: VDC Selection



Connector type: 2.54mm pitch 1×3-pin header.

Pin	Voltage	
1-2	+12V (Default)	
2-3	+VDC (5~20V)	

For **ATX 12V**, select **JVIN (2-3)** & **JVDC (1-2)**



⑨JPSON1: Force ATX Power Supply Power On

Connector type: 2.54mm pitch 1×2-pin header.

Pin	AT/ATX Mode Select	
Short	AT mode	
Open	ATX Mode (default)	



⑩J5VSB1: CPU Module 5VSB Power Selection

Connector type: 2.54mm pitch 1×2-pin header.

Pin	CPU Module 5VSB Power	
Short	5VSB (default)	
Open	Non-Standby power	



⑪JPWOK1: Carrier Board Power OK Selection

Connector type: 2.54mm pitch 1×3 pin header.

Pin	Power Button	
1-2	From carrier board power OK out (default)	
2-3	Always high	

⑫JWDT1: Watchdog Source Selection



Connector type: 2.54mm pitch 1×3 pin header.

Pin	Source	
1-2	Carrier Super I/O (default)	
2-3	CPU module	

⑬JAUDIO1: AUDIO Voltage Selection

The voltage of AUDIO could be selected by JAUDIO1 in +1.5V or +3.3V.



Connector type: 2.54mm pitch 1×3 pin header.

Pin	Voltage	
1-2	+3.3V (default)	
2-3	+1.5V	

SCDB-5293

JCON1: Super I/O Address Selection

Connector type: 2.54mm pitch 1×3 pin header.

Pin	Power Button	
1-2	4EH	
2-3	2EH (default)	

Connectors

① KBM1: PS/2 Keyboard & Mouse Connector

Standard PS/2 Keyboard & Mouse connector
Connector type: double stack 6-pin mini DIN.

Pin	Description
1	KB Data
2	NC
3	GND
4	+5V
5	KB Clock
6	NC
7	MS Data
8	NC
9	GND
10	+5V
11	MS Clock
12	NC

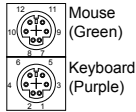

② VGA1: Analog RGB & DVI-D Display Connector

Connector type: VGA: D-Sub 15-pin female.
DVI-D: DVI-D female.

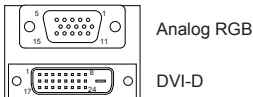

Analog RGB Connector		DVI-D Connector	
Pin	Description	Pin	Description
1	Red	9	+5V
2	Green	10	GND
3	Blue	11	Reserve
4	Reserve	12	DDC_Data
5	GND	13	Horizontal Sync
6	Red Return (GND)	14	Vertical Sync
7	Green Return (GND)	15	DDC_Clock
8	Blue Return (GND)		

DVI-D Connector

Pin	Description	Pin	Description
1	TMDS Data 2-	13	NC
2	TMDS Data 2+	14	+5V
3	TMDS Data 2/4 shield	15	GND (for +5V)
4	NC	16	Hot plug detect
5	NC	17	TMDS Data 0-
6	DDC clock	18	TMDS Data 0+
7	DDC data	19	TMDS Data 0/5 shield
8	NC/Analog vertical sync	20	NC
9	TMDS Data 1-	21	NC
10	TMDS Data 1+	22	TMDS clock shield
11	TMDS Data 1/3 shield	23	TMDS clock+
12	NC	24	TMDS clock-

③④ USB1, 2: Double Stack USB Type A Connectors

Connector type: double stack USB 3.0 type A connector.

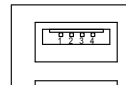

⑤ LAN1: RJ-45 & Double Stack USB Connector

This connector supports USB 2.0 ×2 and Gigabit RJ-45 Ethernet Connector.
Connector type: RJ-45 + double stack USB type A connector.

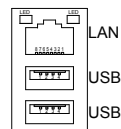

⑥ AUDIO1: HD AUDIO Connector

Azalia Audio supports 7.1-channel audio.
Connector type: 2 × triple stack audio jacks (Stereo ø3.50).



⑦ ⑨ PCIE1, 2: PCIe1 Slots

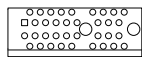

The pin assignments conform to the industry standard.

⑧ PCEG1: PCIe16 Slot

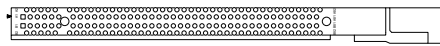

The pin assignments conform to the industry standard.

⑩ PCIE3: PCIe4 Slot

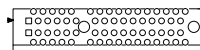

The pin assignments conform to the industry standard.

⑪ ⑩ SYSF1&CPUF1: Fan Power Connectors

The fan must be a +12V fan.
Connector type: 2.54mm pitch 1×3 wafer one wall connector.

Pin	Description
1	GND
2	+12V
3	Fan_Detect



⑫ ⑬ CON1, 2: Ultra Serial Ports

Connector type: 2.54mm pitch 1×5 pin header.

Pin	Description
1	+3.3V
2	NC
3	RX
4	GND
5	TX



⑭ ⑮ MC1, 2: PCI Express Mini-card Sockets

The pin assignments conform to the industry standard.



⑯ ⑰ COM1~6: RS-232 Serial Ports

Connector type: 2.54mm pitch 2×5 box header.

Pin	Desc.	Pin	Desc.
1	DCD#	2	RXD
3	TXD	4	DTR#
5	GND	6	DSR#
7	RTS#	8	CTS#
9	RI#	10	NC

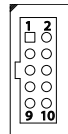

Note. SIO F71869 supports 2 COM ports (COM1~2)

⑱ LPT1: Parallel Port Connector

Connector type: 2.00mm pitch 2×13 box header.

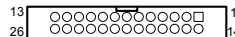

The pin assignments conform to the industry standard.

②3 OPM_J1&2:SIO Module Connectors

J1

Pin	Desc.	Pin	Desc.
1	+V3.3S	2	+V3.3S
3	3V_DUAL	4	3V_DUAL
5	N/C	6	N/C
7	GND	8	VIN2
9	VIN6	10	VIN5
11	VIN4	12	VREF
13	D-	14	D1+
15	D3+	16	GND
17	H_RCIN#	18	HWM_BEEP
19	GND	20	DTIMING_GPIO
21	SIO_PECI	22	GND
23	N/C	24	N/C
25	N/C	26	N/C
27	N/C	28	N/C
29	N/C	30	N/C
31	N/C	32	N/C
33	N/C	34	N/C
35	N/C	36	N/C
37	N/C	38	N/C
39	N/C	40	N/C
41	N/C	42	N/C
43	N/C	44	N/C
45	N/C	46	N/C
47	N/C	48	N/C
49	N/C	50	GND
51	GND	52	N/C
53	N/C	54	N/C
55	N/C	56	N/C
57	N/C	58	N/C
59	N/C	60	N/C
61	N/C	62	N/C
63	N/C	64	SIO_PECI
65	GND	66	SIO_WDTO#
67	THRM#	68	SIO_BKLTCTL1
69	H_A20GATE	70	GND
71	N/C	72	SIO_PME#

73	SMBCLK	74	SMBDATA
75	GND	76	PM_RSMRST
77	LPC_S5#	78	LPC_S3#
79	PWROK	80	ICH_DRQ#1
81	PWSIN#	82	PWSOUT#
83	SIO_PSON#	84	GND
85	LPCCLK_SIO	86	CH_DRQ#0
87	CB_RESET1#	88	INT_SERIRQ
89	LFRAME#	90	LAD3
91	LAD2	92	LAD1
93	LAD0	94	GND
95	5VSB	96	5VSB
97	5VSB	98	5VSB
99	+V3.3A_BAT	100	+V3.3A_BAT

J2

Pin	Desc.	Pin	Desc.
1	+V3.3S	2	+V3.3S
3	3V_DUAL	4	3V_DUAL
5	GND	6	P_SLCT
7	P_PE	8	P_BUSY
9	P_ACK#	10	P_SLIN#
11	P_INIT#	12	P_ERR#
13	[12] P_AFD#	14	P_STB# [12]
15	P_D0	16	P_D1
17	P_D2	18	P_D3
19	P_D4	20	P_D5
21	P_D6	22	P_D7
23	GND	24	GND
25	RI1#	26	DCD1#
27	DTR1#	28	CTS1#
29	DSR1#	30	RTS1#
31	RXD1	32	TXD1
33	GND	34	GND
35	RI2#	36	DCD2#
37	DTR2#	38	CTS2#
39	DSR2#	40	RTS2#
41	RXD2	42	TXD2
43	GND	44	GND

45	RI3#	46	DCD3#
47	DTR3#	48	CTS3#
49	DSR3#	50	RTS3#
51	RXD3	52	TXD3
53	GND	54	GND
55	RI4#	56	DCD4#
57	DTR4#	58	CTS4#
59	DSR4#	60	RTS4#
61	RXD4	62	TXD4
63	GND	64	GND
65	RI5#	66	DCD5#
67	DTR5#	68	CTS5#
69	DSR5#	70	RTS5#
71	RXD5	72	TXD5
73	GND	74	GND
75	RI6#	76	DCD6#
77	DTR6#	78	CTS6#
79	DSR6#	80	RTS6#
81	RXD6	82	TXD6
83	GND	84	GND
85	IRTX	86	IRRX
87	KBCLK	88	KBDAT
89	MSCLK	90	MSDAT
91	CPUFANINO	92	CPUFANOUTO
93	N/C	94	N/C
95	5VSB	96	5VSB
97	5VSB	98	5VSB
99	+V3.3A_BAT	100	+V3.3A_BAT

②④INV1: LCD Inverter Connectors

Connector type: 2.00mm pitch 1×5 box wafer connector.

Pin	Description
1	+12V(default)/5V
2	GND
3	Backlight on/off
4	Brightness control
5	GND



②⑤②⑦DP1, 2: DisplayPort Connectors

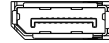

The pin assignments conform to the industry standard.

②⑥LVDS1: LVDS LCD Panel Connectors

The connector supports up to 24-bit dual channel.

Connector type: DF-13-30DP-1.25V.

Pin	Desc.	Pin	Desc.
2	VDD*	1	VDD*
4	TX2CLK+	3	TX1CLK+
6	TX2CLK-	5	TX1CLK-
8	GND	7	GND
10	TX2D0+	9	TX1D0+
12	TX2D0-	11	TX1D0-
14	GND	13	GND
16	TX2D1+	15	TX1D1+
18	TX2D1-	17	TX1D1-
20	GND	19	GND
22	TX2D2+	21	TX1D2+
24	TX2D2-	23	TX1D2-
26	GND	25	GND
28	TX2D3+	27	TX1D3+
30	TX2D3-	29	TX1D3-



*Note: VDD could be selected by JVLCD1 in +5V or +3.3V.

②⑧②⑨③①SATA1~4: SATA Connectors

Connector type: Standard 7-pin SATA Connector.

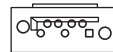

The pin assignments conform to the industry standard.

③③PWRIN1: Power Input Terminal

Connector type: four-pins power terminal

Pin	Desc.
1	VIN+
2	VIN+
3	GND
4	GND

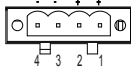

For **5~20V Input**, follow P.10 jumper setting to setup **JVDC/ JVIN** jumper first.

③④ATX1: ATX Power Connector

Connector type: Standard 24-pin Power Connector.

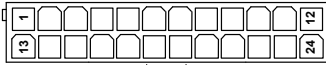

The pin assignments conform to the industry standard.

③⑤DIO1: Digital I/O Connector

DIO1 is a 8-bit GPIO connector.

Connector type: 2.54mm pitch 2x5 pin header.

Pin	Desc.	Pin	Desc.
1	DIO1	2	DIO2
3	DIO3	4	DIO4
5	DIO5	6	DIO6
7	DIO7	8	DIO8
9	+5V	10	GND

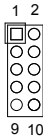

③⑥TPM1: Trusted Platform Module Connector (optional)

Connector type: 2.54mm pitch 2x10 pin header.

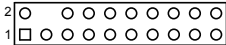

Pin	Description	Pin	Description
1	LPC_CLK(Optional)	2	GND
3	LFRAME#	4	NC (Key)
5	RESET#	6	5V
7	LAD3	8	LAD2
9	+3.3V	10	LAD1
11	LAD0	12	GND
13	SMB_CLK(Optional)	14	SMB_DATA(Optional)
15	+3.3VSB	16	SERIRQ
17	GND	18	NC
19	PD#(Optional)	20	LDRQ#(Optional)

③⑦JFRT1: Switches and Indicators Connector

Connector type: 2.54mm pitch 2x8 pin header.

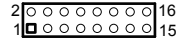

Pin	Description	Pin	Description
1	Power LED+	2	PWRBTN+
3	Power LED-	4	PWRBTN-
5	Power LED-	6	RESET+
7	HDD LED+	8	RESET-
9	HDD LED-	10	SPEAKER+
11	SMBCLK	12	SPEAKER+
13	SMBDATA	14	SPEAKER-
15	GND	16	SPEAKER-