EmETXe-i91M0

**COM Express® Basic
Type 6 CPU Module**

User's Manual

Version 1.2

Revision History

Version	Date	Description
1.0	2019.06	Initial release
1.1	2020.03	1.4 Packing List and 1.6 Optional Accessories 3-pin wafer pitch fan cable revised to be standard package content
1.2	2021.12	Revise 1.5 Ordering Information

Preface	iii
Copyright Notice.....	iii
Declaration of Conformity	iii
CE.....	iii
FCC Class B	iii
RoHS.....	iv
SVHC / REACH.....	iv
Warning	v
Replacing the Lithium Battery.....	v
Technical Support	v
Warranty	vi
Chapter 1 - Introduction	1
1.1 The Product.....	2
1.2 About This Manual.....	2
1.3 Specifications	3
1.4 Packing List	4
1.5 Ordering Information.....	4
1.6 Optional Accessories	5
1.7 Driver(7.3A) Installation	5
Chapter 2 - Board Overview	7
2.1 What Is “COM Express®”?	8
2.2 Board Dimensions.....	9
2.3 Block Diagram	10
2.4 Connector Pin Definition	11
Chapter 3 - Installation & Maintenance	15
3.1 Installing the Heatsink	16
3.2 Installing the CPU Module on Carrier Board.....	17
Chapter 4 - BIOS	19
4.1 Main	20
4.2 Advanced.....	22
4.2.1 CPU Configuration	24
4.2.2 Power & Performance	25

4.2.3	AMT Configuration	26
4.2.4	Trusted Computing.....	27
4.2.5	ACPI Settings.....	28
4.2.6	FAN2 Smart Settings.....	29
4.2.7	PCI Subsystem Settings	30
4.2.8	NVMe Configuration.....	31
4.2.9	USB Configuration	32
4.2.10	Hardware Monitor.....	34
4.2.11	Super IO Configuration	35
4.2.12	S5 RTC Wake Settings	38
4.2.13	Serial Port Console Redirection.....	39
4.2.14	Network Stack Configuration	41
4.2.15	CSM Configuration.....	43
4.3	Chipset	44
4.3.1	System Agent (SA) Configuration.....	45
4.3.2	PCH-IO Configuration	47
4.4	Security	51
4.5	Boot	52
4.6	Save & Exit.....	53
Appendix		55
Appendix A: I/O Port Address Map		56
Appendix B: Interrupt Request Lines (IRQ)		57
Appendix C: Watchdog Timer (WDT) Setting.....		58
Appendix D: DIO Sample Code		60

Copyright Notice

All Rights Reserved.

The information in this document is subject to change without prior notice in order to improve the reliability, design and function. It does not represent a commitment on the part of the manufacturer.

Under no circumstances will the manufacturer be liable for any direct, indirect, special, incidental, or consequential damages arising from the use or inability to use the product or documentation, even if advised of the possibility of such damages.

This document contains proprietary information protected by copyright. All rights are reserved. No part of this manual may be reproduced by any mechanical, electronic, or other means in any form without prior written permission of the manufacturer.

Declaration of Conformity

CE

The CE symbol on your product indicates that it is in compliance with the directives of the Union European (EU). A Certificate of Compliance is available by contacting Technical Support.

This product has passed the CE test for environmental specifications when shielded cables are used for external wiring. We recommend the use of shielded cables. This kind of cable is available from ARBOR. Please contact your local supplier for ordering information.

This product has passed the CE test for environmental specifications. Test conditions for passing included the equipment being operated within an industrial enclosure. In order to protect the product from being damaged by ESD (Electrostatic Discharge) and EMI leakage, we strongly recommend the use of CE-compliant industrial enclosure products.

Warning

This is a class A product. In a domestic environment this product may cause radio interference in which case the user may be required to take adequate measures.

FCC Class B

This device complies with Part 15 of the FCC Rules. Operation is subject to the following two conditions:

- (1) This device may not cause harmful interference, and
- (2) This device must accept any interference received, including interference that may cause undesired operation.

NOTE:

This equipment has been tested and found to comply with the limits for a Class A digital device, pursuant to Part 15 of the FCC Rules. These limits are designed to provide reasonable protection against harmful interference when the equipment is operated in a commercial environment. This equipment generates, uses, and can radiate radio frequency energy and, if not installed and used in accordance with the instruction manual, may cause harmful interference to radio communications. Operation of this equipment in a residential area is likely to cause harmful interference in which case the user will be required to correct the interference at his own expense.

RoHS

ARBOR Technology Corp. certifies that all components in its products are in compliance and conform to the European Union's Restriction of Use of Hazardous Substances in Electrical and Electronic Equipment (RoHS) Directive 2002/95/EC.

The above mentioned directive was published on 2/13/2003. The main purpose of the directive is to prohibit the use of lead, mercury, cadmium, hexavalent chromium, polybrominated biphenyls (PBB), and polybrominated diphenyl ethers (PBDE) in electrical and electronic products. Member states of the EU are to enforce by 7/1/2006.

ARBOR Technology Corp. hereby states that the listed products do not contain unintentional additions of lead, mercury, hex chrome, PBB or PBDB that exceed a maximum concentration value of 0.1% by weight or for cadmium exceed 0.01% by weight, per homogenous material. Homogenous material is defined as a substance or mixture of substances with uniform composition (such as solders, resins, plating, etc.). Lead-free solder is used for all terminations (Sn(96-96.5%), Ag(3.0-3.5%) and Cu(0.5%)).

SVHC / REACH

To minimize the environmental impact and take more responsibility to the earth we live, Arbor hereby confirms all products comply with the restriction of SVHC (Substances of Very High Concern) in (EC) 1907/2006 (REACH --Registration, Evaluation, Authorization, and Restriction of Chemicals) regulated by the European Union.

All substances listed in SVHC < 0.1 % by weight (1000 ppm)

Warning

Single Board Computers and their components contain very delicate Integrated Circuits (IC). To protect the Single Board Computer and its components against damage from static electricity, you should always follow the following precautions when handling it :

1. Disconnect your Single Board Computer from the power source when you want to work on the inside.
2. Hold the board by the edges and try not to touch the IC chips, leads or circuitry.
3. Use a grounded wrist strap when handling computer components.
4. Place components on a grounded antistatic pad or on the bag that comes with the Single Board Computer, whenever components are separated from the system.

Replacing the Lithium Battery

Incorrect replacement of the lithium battery may lead to a risk of explosion.

The lithium battery must be replaced with an identical battery or a battery type recommended by the manufacturer.

Do not throw lithium batteries into the trash-can. It must be disposed of in accordance with local regulations concerning special waste.

Technical Support

If you have any technical difficulties, please contact our website at:

<https://www.arbor-technology.com>

Warranty

This product is warranted to be in good working order for a period of two years from the date of purchase. Should this product fail to be in good working order at any time during this period, we will, at our option, replace or repair it at no additional charge except as set forth in the following terms. This warranty does not apply to products damaged by misuse, modifications, accident or disaster.

Vendor assumes no liability for any damages, lost profits, lost savings or any other incidental or consequential damage resulting from the use, misuse of, or inability to use this product. Vendor will not be liable for any claim made by any other related party.

Vendors disclaim all other warranties, either expressed or implied, including but not limited to implied warranties of merchantability and fitness for a particular purpose, with respect to the hardware, the accompanying product's manual(s) and written materials, and any accompanying hardware. This limited warranty gives you specific legal rights.

Return authorization must be obtained from the vendor before returned merchandise will be accepted. Authorization can be obtained by calling or faxing the vendor and requesting a Return Merchandise Authorization (RMA) number. Returned goods should always be accompanied by a clear problem description.



Chapter 1

Introduction

1.1 The Product

The EmETXe-i91M0 is a space-conscious CPU board of 125 mm x 95 mm to take up only small footprint in your system. By the architecture of Type 6, the board has two high-performance connectors to promise stable data passing rate. The soldered onboard 8th Generation Intel® Core™ processor, along with integrated Intel® Graphics chipset, bring LVDS, and DDI solution for most monitors or LCD video panels.

For system configuration, the board is supported by AMI UEFI BIOS. EmETXe-i91M0 is an ideal choice for some demanding industrial control and data communications by its significant processing performance, low power consumption and these features:

- Soldered onboard 8th Generation Intel® i7/i5/i3 processors
- Intel WGI219LM PCIe GbE PHY w/ iAMT
- Dual Channels 24-bit LVDS / Analog RGB or DP
- Support 3 independent displays
- 8.5V~20V Wide Range Voltage Input
- Wide Range Operating Temp.: -40 ~ 85°C

1.2 About This Manual

This user's manual provides general information and installation instructions about the product. This user's manual is intended for experienced users and integrators with hardware knowledge of personal computers. If you are not sure about any description in this booklet. Please consult your vendor before further handling.

1.3 Specifications

System	
CPU	Soldered onboard 8/9 th Generation Intel® Core™ Coffee Lake-H processors
Chipset	Intel® QM370
Memory	2 x DDR4 SO-DIMM sockets
BIOS	AMI UEFI BIOS
Watchdog Timer	1~255 levels reset
I/O	
USB Port	12 x USB ports: - 8 x USB 2.0 ports - 4 x USB 3.1 ports
Serial Port	2 x UART ports (RX/TX only)
Expansion Bus	8 x PCIe x1 lanes, 1 x PCIe x16 lane, I2C Interface,GPIO
Storage	4 x Serial ATA ports with 600MB/s HDD transfer rate
Ethernet Chipset	1 x Intel® i219LM PCIe GbE PHY
Audio	HD audio link
TPM	TPM 2.0
Display	
Graphic Chipset	Integrated Intel® UHD Graphics 630
Graphic Interface	LCD: Dual Channels 24-bit LVDS/ 3 x DDI ports or Analog RGB/ 2 x DDI port
Mechanical & Environmental	
Power Requirement	8.5V~20V +/- 5% wide range voltage input, +5VSB
Power Consumption	8.93A@12V (i7-8850H Typical)
Operating Temp.	-40 ~ 85°C (-40 ~ 185°F)
Operating Humidity	10 ~ 95% @ 85°C (non-condensing)
Dimensions (L x W)	125 x 95 mm (4.9" x 3.7")

1.4 Packing List

Before you begin installing your single board, please make sure that the following materials have been shipped:



1 x EmETXe-i91M0 COM Express CPU Module



1 x Quick Installation Guide



1 x Fan Cable

If any of the above items is damaged or missing, contact your vendor immediately.

1.5 Ordering Information

EmETXe-i91M0-WT-9850HE	9 th Generation Intel® Core™ i7-9850HE, w/o Analog RGB WT COM Express® Basic Type 6 CPU Module
EmETXe-i91M0-WT-9850HE-RGB	9 th Generation Intel® Core™ i7-9850HE, w/ Analog RGB WT COM Express® Basic Type 6 CPU Module
EmETXe-i91M0-WT-8850H	8 th Generation Intel® Core™ i7-8850H, w/o Analog RGB WT COM Express® Basic Type 6 CPU Module
EmETXe-i91M0-WT-8850H-RGB	8 th Generation Intel® Core™ i7-8850H, w/ Analog RGB WT COM Express® Basic Type 6 CPU Module
EmETXe-i91M0-WT-8400H	8 th Generation Intel® Core™ i5-8400H, w/o Analog RGB WT COM Express® Basic Type 6 CPU Module
EmETXe-i91M0-WT-8400H-RGB	8 th Generation Intel® Core™ i5-8400H, w/ Analog RGB WT COM Express® Basic Type 6 CPU Module
EmETXe-i91M0-WT-8100H	8 th Generation Intel® Core™ i3-8100H, w/o Analog RGB WT COM Express® Basic Type 6 CPU Module
EmETXe-i91M0-WT-8100H-RGB	8 th Generation Intel® Core™ i3-8100H, w/ Analog RGB WT COM Express® Basic Type 6 CPU Module

1.6 Optional Accessories

HS-91M0-C1	Heat sink with Fan, with PAD(125x95x50mm)
PBE-1705-F1	COM Express® Type 6 evaluation carrier board with SIO F71869ED module in ATX form factor
CBK-03-1705-00	Cable kit 1 x SATA cable 2 x COM Flat cables

1.7 Driver(7.3A) Installation

To install the drivers, please visit our website at www.arbor-technology.com and download the driver pack from the product page.

Windows 10 64-bit

Driver	Path
Chipset	\EmETXe-i91M0\Chipset
Graphic	\EmETXe-i91M0\Graphic\win64
Audio	\EmETXe-i91M0\Audio\Win10_Win8.1_Win8_Win7_WHQLx64
Ethernet	\EmETXe-i91M0\Ethernet
ME	\EmETXe-i91M0\ME
RST	\EmETXe-i91M0\RST\SetupRST

This page is intentionally left blank.



Chapter 2

Board Overview

2.1 What Is “COM Express®”?

With more and more demands on small and embedded industrial boards, a multi-functional COM (Computer-on-Module) surfaces as a great solution.

COM Express® supports seven pin-out types applying to Basic and Extended form factors:

Module Type 1 and 10 support single connector with two rows (220 pins).

Module Type 2, 3, 4, 5 and 6 support two connectors with four rows (440 pins).

EmETXe-i91M0 is a Type-6 module.

Difference between Standard Type 6 and EmETXe-i91M0 is listed as below:

Module Type	Standard Type 6	EmETXe-i91M0
Connectors	2	2
Connector Rows	A, B, C, D	A, B, C, D
PCIe Lanes (Max)	24	24
LAN (Max)	1	1
Serial Ports (Max)	2	2
Digital Display I/F (Max)	3	3
USB 3.1 Ports (Max)	4	4

Row AB provides pins for PCI Express, SATA, LVDS, LCD channel, LPC bus, system and power management, VGA, LAN, and power and ground interfaces.

Row CD provides SDVO and legacy PCI signals next to additional PCI Express, LAN and power and ground signals. The COM are targeted at following applications:

- Retail & Advertising
- Medical
- Test & Measurement
- Gaming & Entertainment
- Industrial & Automation
- Military & Government
- Security

2.2 Board Dimensions

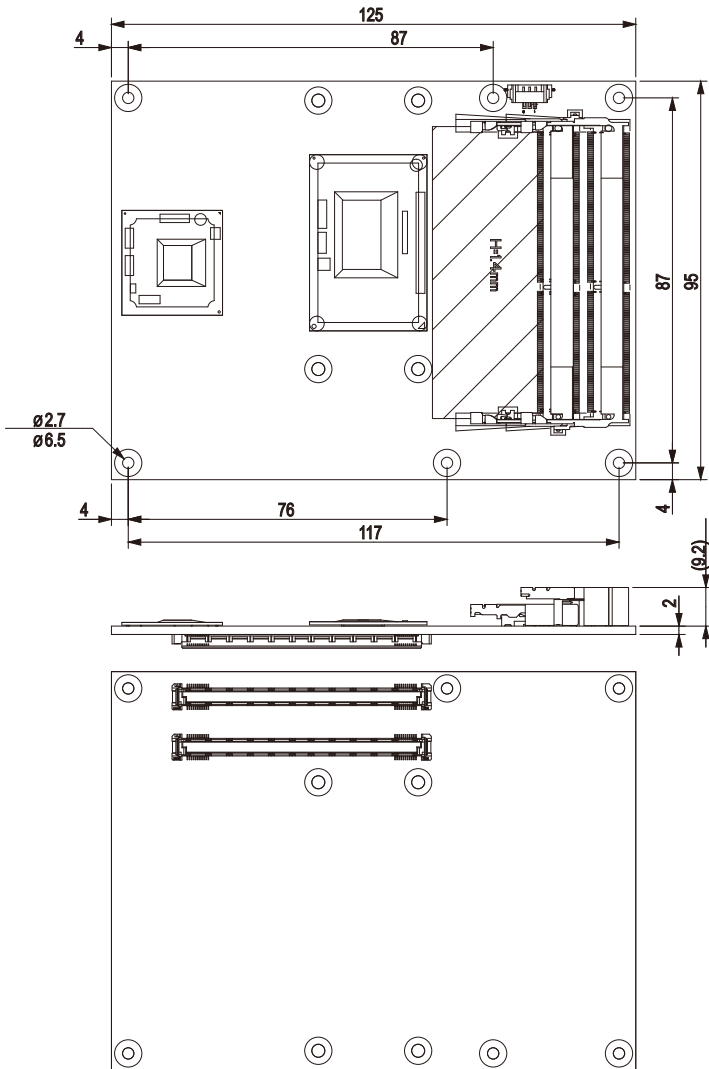

Unit: mm

2.3 Block Diagram

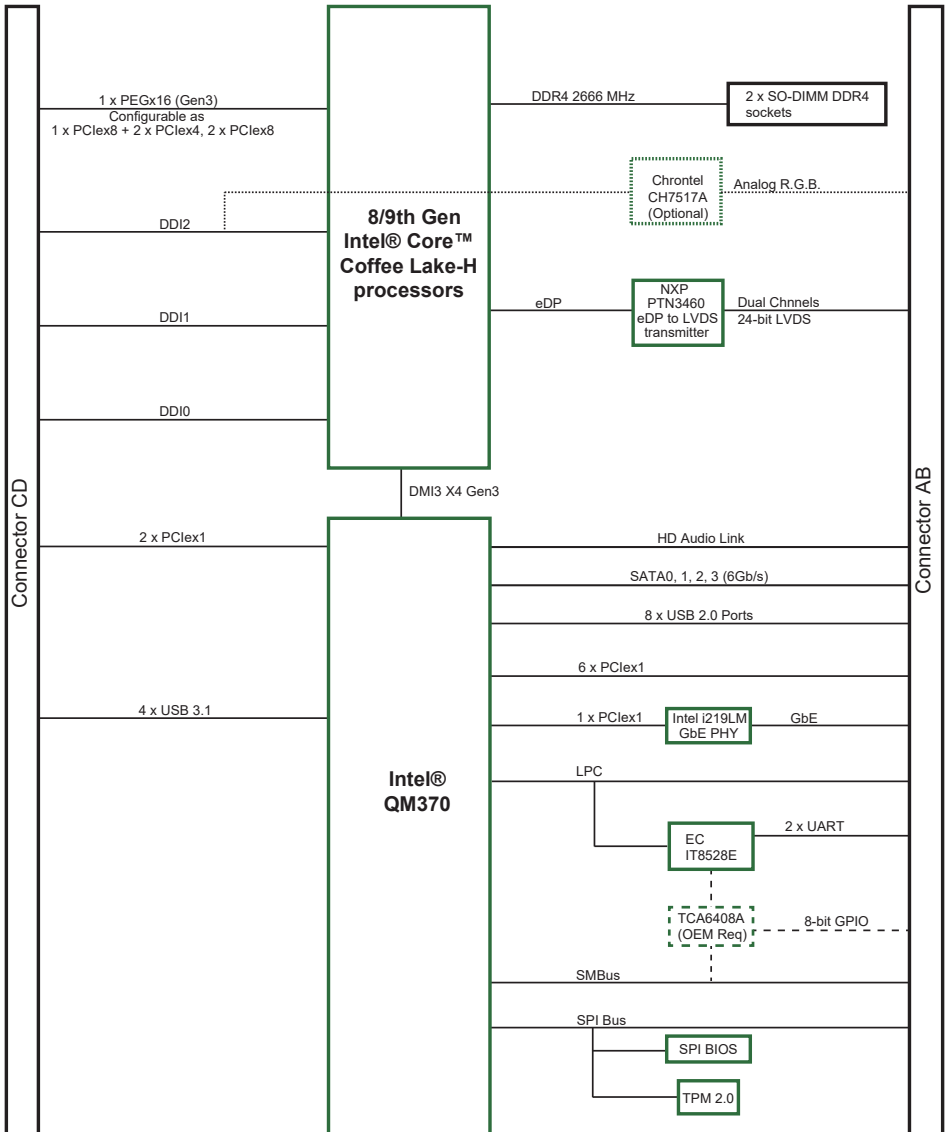

2.4 Connector Pin Definition

Being a most commonly-used Type 6, the EmETXe-i91M0 features two board-to-board connectors on bottom side.

Top Side

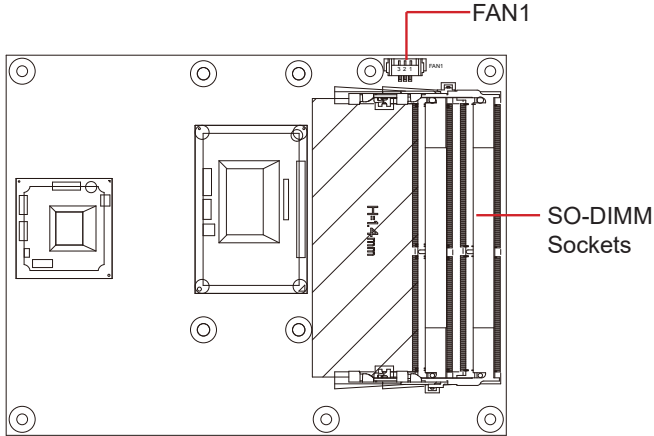

Bottom Side

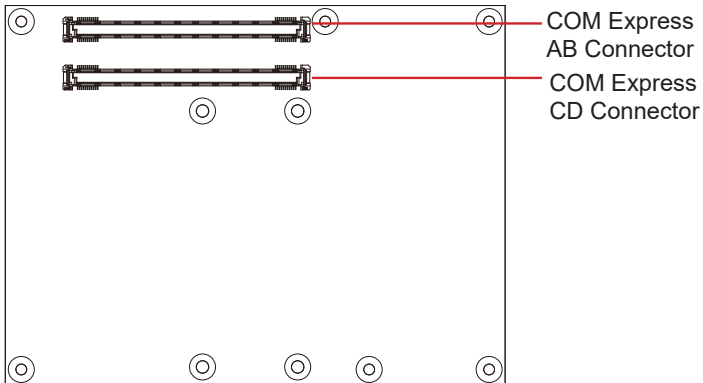

FAN1: Fan connector

Connector type: Wafer 3-pin 1.25mm 85204-03X0L

Pin	Description
1	GND
2	Fan out
3	Fan Tachometer Input



COM Express AB Connector (bottom side)

B1	GND (FIXED)	GND (FIXED)	A1	B56	PCIE_RX9-	PCIE_TX9-	A56
B2	GBE0_ACT#	GBE0_MDI3-	A2	B57	DIO_6	GND	A57
B3	LPC_FRAME#	GBE0_MDI3+	A3	B58	PCIE_RX4+	PCIE_TX4+	A58
B4	LPC_AD0	GBE0_LINK100#	A4	B59	PCIE_RX4-	PCIE_TX4-	A59
B5	LPC_AD1	GBE0_LINK100#	A5	B60	GND	GND	A60
B6	LPC_AD2	GBE0_MDI2-	A6	B61	PCIE_RX3+	PCIE_TX3+	A61
B7	LPC_AD3	GBE0_MDI2+	A7	B62	PCIE_RX3-	PCIE_TX3-	A62
B8	LPC_DRQ0#	GBE0_LINK#	A8	B63	DIO_7	DIO_7	A63
B9	LPC_DRQ1#	GBE0_MDI1-	A9	B64	PCIE_RX2+	PCIE_TX2+	A64
B10	LPC_CLK	GBE0_MDI1+	A10	B65	PCIE_RX2-	PCIE_TX2-	A65
B11	GND (FIXED)	GND (FIXED)	A11	B66	PCH_WAKE#	GND	A66
B12	CB_PWRBTN#	GBE0_MDI0-	A12	B67	EC_WAKE_IN#	DIO_2	A67
B13	CB_SMB_CLK	GBE0_MDI0+	A13	B68	PCIE_RX1+	PCIE_TX1+	A68
B14	CB_SMB_DAT	N/C	A14	B69	PCIE_RX1-	PCIE_TX1-	A69
B15	CB_SMB_ALERT#	SLP_S3#	A15	B70	GND	GND	A70
B16	SATA1_TX+	SATA0_TX+	A16	B71	LVDSB_DATA0+	LVDSA_DATA0+	A71
B17	SATA1_TX-	SATA0_TX-	A17	B72	LVDSB_DATA0-	LVDSA_DATA0-	A72
B18	SUS_STAT#	SLP_S4#	A18	B73	LVDSB_DATA1+	LVDSA_DATA1+	A73
B19	SATA1_RX+	SATA0_RX+	A19	B74	LVDSB_DATA1-	LVDSA_DATA1-	A74
B20	SATA1_RX-	SATA0_RX-	A20	B75	LVDSB_DATA2+	LVDSA_DATA2+	A75
B21	GND (FIXED)	GND (FIXED)	A21	B76	LVDSB_DATA2-	LVDSA_DATA2-	A76
B22	SATA3_TX+	SATA2_TX+	A22	B77	LVDSB_DATA3+	LVDS_VDD_EN	A77
B23	SATA3_TX-	SATA2_TX-	A23	B78	LVDSB_DATA3-	LVDSA_DATA3+	A78
B24	CB_PWROK	SLP_S5#	A24	B79	LVDSBKLTEN	LVDSA_DATA3-	A79
B25	SATA3_RX+	SATA2_RX+	A25	B80	GND	GND	A80
B26	SATA3_RX-	SATA2_RX-	A26	B81	LVDSB_CLK+	LVDSA_CLK+	A81
B27	WDT	PM_BATLOW#	A27	B82	LVDSB_CLK-	LVDSA_CLK-	A82
B28	N/C	SATALED-	A28	B83	COM_BKLT_CTRL	LVDS_CK_EDP_AUXP	A83
B29	HDA_SDIN1	HDA_SYNC	A29	B84	VCC_5V_SBY	LVDS_DAT_EDP_AUXN	A84
B30	HDA_SDINO	HDA_RST#	A30	B85	VCC_5V_SBY	DIO_3	A85
B31	GND	GND	A31	B86	VCC_5V_SBY	H_RCIN	A86
B32	SPKR	HDA_BITCLK	A32	B87	VCC_5V_SBY	EDP_HPD(Optional)	A87
B33	I2C_CK	HDA_SDOUT	A33	B88	BIOS_DISABLE1#	COM_CLK+	A88
B34	I2C_DAT	BIOS_DISABLE0#	A34	B89	CRT_RED	COM_CLK-	A89
B35	THR#	CB_TRIP#	A35	B90	GND	GND	A90
B36	USB7-	USB6-	A36	B91	CRT_GREEN	SPI_POWER	A91
B37	USB7+	USB6+	A37	B92	CRT_BLUE	SPI_MISO	A92
B38	USB_4_5_OC#	USB_6_7_OC#	A38	B93	CRT_HSYNC	DIO_4	A93
B39	USB5-	USB4-	A39	B94	CRT_VSYNC	SPL_CK	A94
B40	USB5+	USB4+	A40	B95	CRT_DDC_CLK	SPI_MOSI	A95
B41	GND	GND	A41	B96	CRT_DDC_DATA	COM_TPM_PP	A96
B42	USB3-	USB2-	A42	B97	SPL_CS1#	N/C	A97
B43	USB3+	USB2+	A43	B98	N/C	UART_TX0	A98
B44	USB_0_1_OC#	USB_2_3_OC#	A44	B99	N/C	UART_RX0	A99
B45	USB1-	USB0-	A45	B100	GND	GND	A100
B46	USB1+	USB0+	A46	B101	FAN_PWMOUT	UART_TX1	A101
B47	PLTRST#_BUFF	VRTC_BT	A47	B102	FAN_TACHIN	UART_RX1	A102
B48	EXCD1_CCPE#	PLTRST#_BUFF	A48	B103	SLEEP#	LID#	A103
B49	SYS_RESET#	EXCD0_CCPE#	A49	B104	VCC_12V	VCC_12V	A104
B50	CB_RESET#	LPC_SERIRQ	A50	B105	VCC_12V	VCC_12V	A105
B51	GND	GND	A51	B106	VCC_12V	VCC_12V	A106
B52	PCIE_RX10+	PCIE_TX10+	A52	B107	VCC_12V	VCC_12V	A107
B53	PCIE_RX10-	PCIE_TX10-	A53	B108	VCC_12V	VCC_12V	A108
B54	DIO_5	DIO_0	A54	B109	VCC_12V	VCC_12V	A109
B55	PCIE_RX9+	PCIE_TX9+	A55	B110	GND	GND	A110

COM Express CD Connector (bottom side)

D1	GND (FIXED)	GND (FIXED)	C1	D56	PEG_TX1-	PEG_RX1-	C56
D2	GND	GND	C2	D57	TYPE2#	N/C	C57
D3	USB3_TX1-	USB3_RX1-	C3	D58	PEG_TX2+	PEG_RX2+	C58
D4	USB3_TX1+	USB3_RX1+	C4	D59	PEG_TX2-	PEG_RX2-	C59
D5	GND	GND	C5	D60	GND (FIXED)	GND (FIXED)	C60
D6	USB3_TX2-	USB3_RX2-	C6	D61	PEG_TX3+	PEG_RX3+	C61
D7	USB3_TX2+	USB3_RX2+	C7	D62	PEG_TX3-	PEG_RX3-	C62
D8	GND	GND	C8	D63	N/C	N/C	C63
D9	USB3_TX3-	USB3_RX3-	C9	D64	N/C	N/C	C64
D10	USB3_TX3+	USB3_RX3+	C10	D65	PEG_TX4+	PEG_RX4+	C65
D11	GND (FIXED)	GND (FIXED)	C11	D66	PEG_TX4-	PEG_RX4-	C66
D12	USB3_TX4-	USB3_RX4-	C12	D67	GND	N/C	C67
D13	USB3_TX4+	USB3_RX4+	C13	D68	PEG_TX5+	PEG_RX5+	C68
D14	GND	GND	C14	D69	PEG_TX5-	PEG_RX5-	C69
D15	DDI2_CLK_AUX+	N/C	C15	D70	GND (FIXED)	GND (FIXED)	C70
D16	DDI2_CLK_AUX-	N/C	C16	D71	PEG_TX6+	PEG_RX6+	C71
D17	N/C	N/C	C17	D72	PEG_TX6-	PEG_RX6-	C72
D18	N/C	N/C	C18	D73	GND	GND	C73
D19	PCIE_TX11+	PCIE_RX11+	C19	D74	PEG_TX7+	PEG_RX7+	C74
D20	PCIE_TX11-	PCIE_RX11-	C20	D75	PEG_TX7-	PEG_RX7-	C75
D21	GND (FIXED)	GND (FIXED)	C21	D76	GND	GND	C76
D22	PCIE_TX12+	PCIE_RX12+	C22	D77	N/C	N/C	C77
D23	PCIE_TX12-	PCIE_RX12-	C23	D78	PEG_TX8+	PEG_RX8+	C78
D24	N/C	DPB_HPD	C24	D79	PEG_TX8-	PEG_RX8-	C79
D25	N/C	N/C	C25	D80	GND (FIXED)	GND (FIXED)	C80
D26	DDI2_PAIR0+	N/C	C26	D81	PEG_TX9+	PEG_RX9+	C81
D27	DDI2_PAIR0-	N/C	C27	D82	PEG_TX9-	PEG_RX9-	C82
D28	N/C	N/C	C28	D83	N/C	N/C	C83
D29	DDI2_PAIR1+	N/C	C29	D84	GND	GND	C84
D30	DDI2_PAIR1-	N/C	C30	D85	PEG_TX10+	PEG_RX10+	C85
D31	GND (FIXED)	GND (FIXED)	C31	D86	PEG_TX10-	PEG_RX10-	C86
D32	DDI2_PAIR2+	DDI3_CLK_AUX+	C32	D87	GND	GND	C87
D33	DDI2_PAIR2-	DDI3_DATA_AUX-	C33	D88	PEG_TX11+	PEG_RX11+	C88
D34	DDI2_DDC_AUX_SEL	DDI3_DDC_AUX_SEL	C34	D89	PEG_TX11-	PEG_RX11-	C89
D35	N/C	N/C	C35	D90	GND (FIXED)	GND (FIXED)	C90
D36	DDI2_PAIR3+	DDI4_CLK_AUX+	C36	D91	PEG_TX12+	PEG_RX12+	C91
D37	DDI2_PAIR3-	DDI4_CLK_AUX-	C37	D92	PEG_TX12-	PEG_RX12-	C92
D38	N/C	DDI4_DDC_AUX_SEL	C38	D93	GND	GND	C93
D39	DDI3_PAIR0+	DDI4_PAIR_COM_0+	C39	D94	PEG_TX13+	PEG_RX13+	C94
D40	DDI3_PAIR0-	DDI4_PAIR_COM_0-	C40	D95	PEG_TX13-	PEG_RX13-	C95
D41	GND (FIXED)	GND (FIXED)	C41	D96	GND	GND	C96
D42	DDI3_PAIR1+	DDI4_PAIR_COM_1+	C42	D97	N/C	N/C	C97
D43	DDI3_PAIR1-	DDI4_PAIR_COM_1-	C43	D98	PEG_TX14+	PEG_RX14+	C98
D44	DPC_HPD	DPD_HPD_COM	C44	D99	PEG_TX14-	PEG_RX14-	C99
D45	N/C	N/C	C45	D100	GND (FIXED)	GND (FIXED)	C100
D46	DDI3_PAIR2+	DDI4_PAIR2+	C46	D101	PEG_TX15+	PEG_RX15+	C101
D47	DDI3_PAIR2-	DDI4_PAIR2-	C47	D102	PEG_TX15-	PEG_RX15-	C102
D48	N/C	N/C	C48	D103	GND	GND	C103
D49	DDI3_PAIR3+	DDI4_PAIR3+	C49	D104	VCC_12V	VCC_12V	C104
D50	DDI3_PAIR3-	DDI4_PAIR3-	C50	D105	VCC_12V	VCC_12V	C105
D51	GND (FIXED)	GND (FIXED)	C51	D106	VCC_12V	VCC_12V	C106
D52	PEG_TX0+	PEG_RX0+	C52	D107	VCC_12V	VCC_12V	C107
D53	PEG_TX0-	PEG_RX0-	C53	D108	VCC_12V	VCC_12V	C108
D54	PEG_LANE_RV#	N/C	C54	D109	VCC_12V	VCC_12V	C109
D55	PEG_TX1+	PEG_RX1+	C55	D110	GND (FIXED)	GND (FIXED)	C110

This page is intentionally left blank.



Chapter 3

Installation & Maintenance

3.1 Installing the Heatsink

Prepare the heat sink in the optional accessories and follow the steps below to install the heat sink.

1. Connect the fan cable of the heat sink to the fan connector on the CPU module.
2. Find the thermal paste tube included in the heat sink accessory box. Apply the thermal paste to the CPU area.
3. Remove the two tapes of the areas as shown in the picture below.

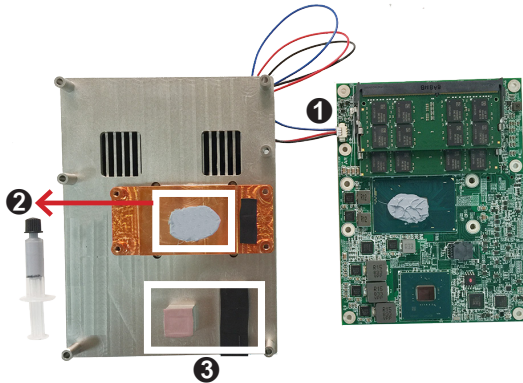

4. Secure the heat sink assembly to the CPU module by fastening the 4 screws included in the heat sink accessory pack.

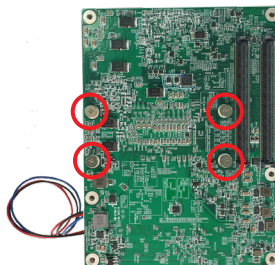

3.2 Installing the CPU Module on Carrier Board

Prepare the carrier board in the optional accessories and follow the steps below to install the CPU module to the carrier board.

1. Mount the Embed EmETXe-i91M0 into PBE-1705 via COM Express connectors as below; that is, COM Express AB to AB and CD to CD.

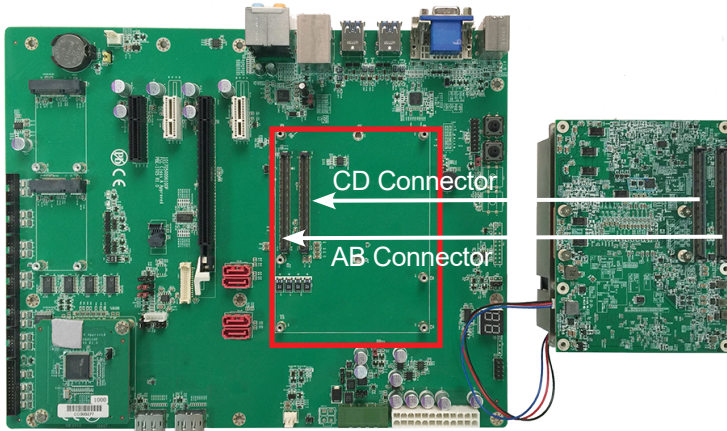

2. Secure the CPU module to the carrier board by fastening the 6 screws included in the heat sink accessory pack.

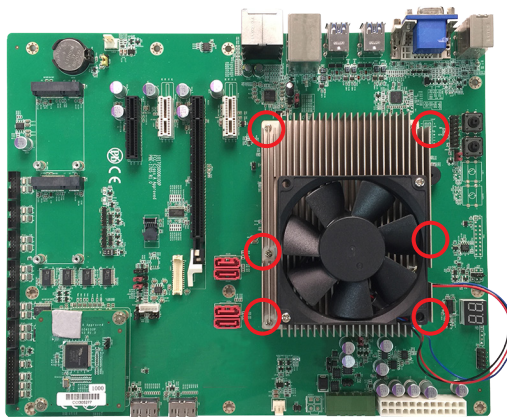

This page is intentionally left blank.

Chapter 4

BIOS

4.1 Main

The AMI BIOS provides a Setup utility program for specifying the system configurations and settings. The BIOS RAM of the system stores the Setup utility and configurations. When you turn on the computer, the AMI BIOS is immediately activated. To enter the BIOS SETUP UTILITY, press “Delete” once the power is turned on.

The **Main Setup** screen lists the following information:

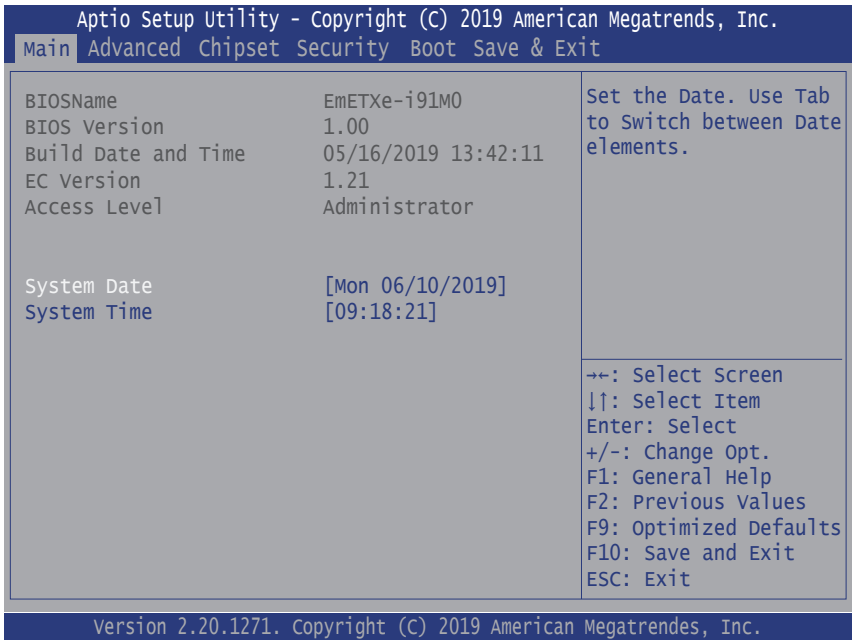

Setting	Description
System Language	Choose the system default language.
System Date	Set the system date. Use Tab to switch between Data elements. Note that the ‘Day’ automatically changes when you set the date. ► The date format is: Day: Sun to Sat Month: 1 to 12 Date: 1 to 31 Year: 1998 to 2099

System Time	<p>Set the system time. Use Tab to switch between Time elements.</p> <p>▶ The time format is: Hour: 00 to 23 Minute: 00 to 59 Second: 00 to 59</p>
-------------	-----------------------------------------------------------------------------------------------------------------------------------------------------------------------------------

Key Commands

BIOS Setup Utility is mainly a key-based navigation interface. Please refer to the following key command instructions for navigation process.

Keystroke	Function
◀ ▶	Move to highlight a particular configuration screen from the top menu bar / Move to highlight items on the screen
▼ ▲	Move to highlight previous/next item
Enter	Select and access a setup item/field
Esc	On the Main Menu – Quit the setup and not save changes into CMOS (a message screen will display and ask you to select “OK” or “Cancel” for exiting and discarding changes. Use “←” and “→” to select and press “Enter” to confirm) On the Sub Menu – Exit current page and return to main menu
Page Up / +	Increase the numeric value on a selected setup item / make change
Page Down / -	Decrease the numeric value on a selected setup item / make change
F1	Activate “General Help” screen
F2	Restore previous values
F9	Use optimized defaults
F10	Save the changes that have been made in the setup and exit. (a message screen will display and ask you to select “OK” or “Cancel” for exiting and saving changes. Use “←” and “→” to select and press “Enter” to confirm)

4.2 Advanced

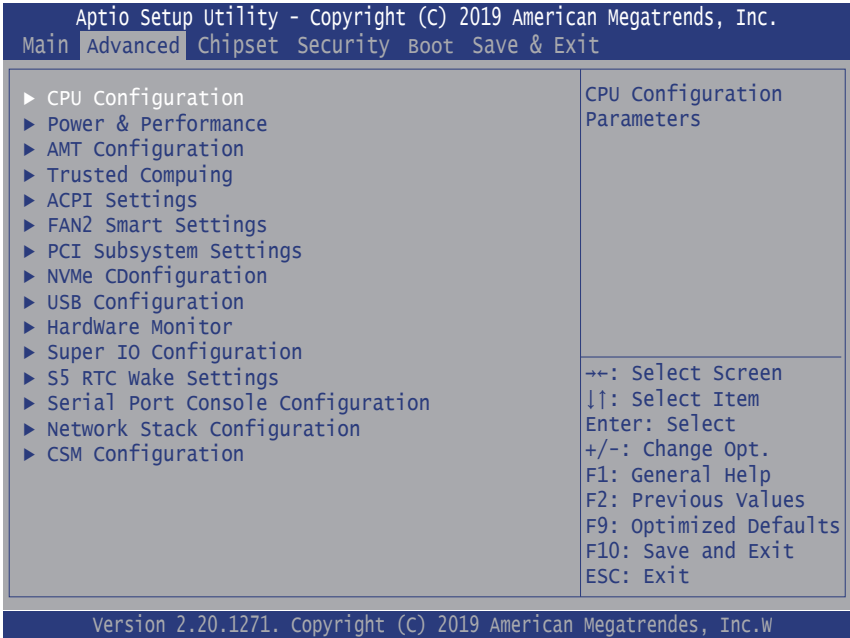

Setting	Description
CPU Configuration	See section 4.2.1 CPU Configuration on page 24
Power & Performance	See section 4.2.2 Power & Performance on page 25
AMT Configuration	See section 4.2.3 AMT Configuration on page 26
Trusted Computing	See section 4.2.4 Trusted Computing on page 27
ACPI Settings	See section 4.2.5 ACPI Settings on page 28
FAN2 Smart Settings	See section 4.2.6 FAN2 Smart Settings on page 29
PCI Subsystem Settings	See section 4.2.7 PCI Subsystem Settings on page 30
NVMe Configuration	See section 4.2.8 NVMe Configuration on page 31
USB Configuration	See section 4.2.9 USB Configuration on page 32
Hardware Monitor	See section 4.2.10 Hardware Monitor on page 34

Super IO Configuration	See section 4.2.11 Super IO Configuration on page 35
S5 RTC Wake Settings	See section 4.2.12 S5 RTC Wake Settings on page 38
Serial Port Console Configuration	See section 4.2.13 Serial Port Console Redirection on page 39
Network Stack Configuration	See section 4.2.14 Network Stack Configuration on page 41
CSM Configuration	See section 4.2.15 CSM Configuration on page 43

4.2.1 CPU Configuration

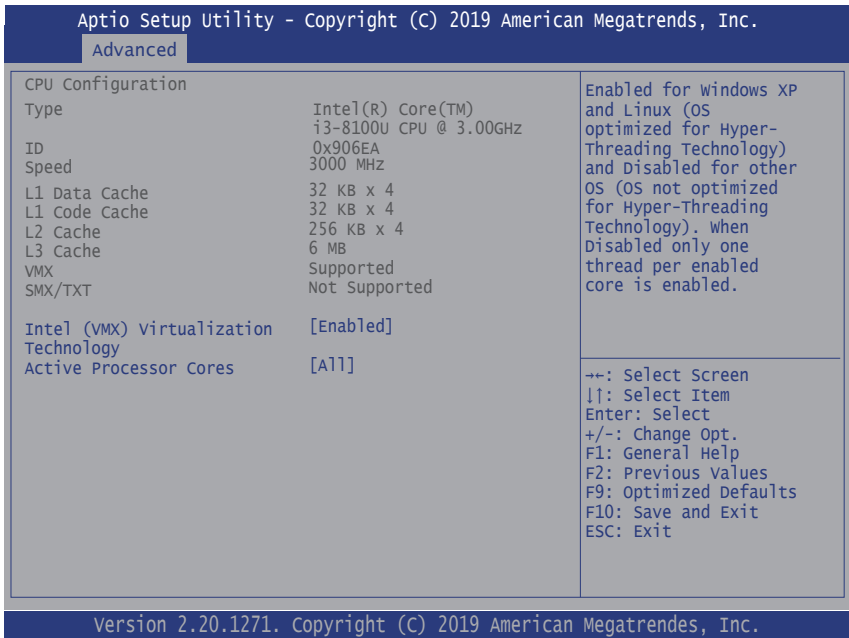

Setting	Description
Intel (VMX) Virtualization Technology	Enable or disable Intel virtualization technology. ► Options: Enabled (default) or Disabled
Active Processor Cores	Number of cores to enable in each processor package. ► Options: All (default) 1 , 2 and 3

4.2.2 Power & Performance

Aptio Setup Utility - Copyright (C) 2019 American Megatrends, Inc.

Advanced

<p>Power & Performance</p> <p>▶ CPU- Power Management Control</p>	<p>CPU - Power Management Control Options</p>
	<p>++: Select Screen : Select Item Enter: Select +/-: Change Opt. F1: General Help F2: Previous Values F3: Optimized Defaults F4: Save and Exit ESC: Exit</p>

Version 2.20.1271. Copyright (C) 2019 American Megatrends, Inc.

Aptio Setup Utility - Copyright (C) 2019W American Megatrends, Inc.

Advanced

<p>CPU- Power Management Control</p> <p>Boot performance mode [Max Non-Turbo Performance]</p> <p>Intel(R) SpeedStep(tm) [Enabled]</p> <p>C states [Disabled]</p>	<p>Select the performance state that the BIOS will set starting from reset vector.</p>
	<p>++: Select Screen : Select Item Enter: Select +/-: Change Opt. F1: General Help F2: Previous Values F3: Optimized Defaults F4: Save and Exit ESC: Exit</p>

Version 2.20.1271. Copyright (C) 2019 American Megatrends, Inc.

Setting	Description
Boot performance Mode	Set the performance state that the BIOS will set before the OS handoff. ▶ Options: Max Non-Turbo Performance (default), Max Battery and Turbo Performance
Intel (R) Speed Step (tm)	Enable (default) / Disable Intel SpeedStep
CPU C States	Enable / Disable (default) CPU C States

4.2.3 AMT Configuration

This setting is not available. Please ignore this setting.

4.2.4 Trusted Computing



Setting	Description
Security Device Support	Enable (default) or Disable BIOS support for security device. O.S. will not show Security Device. TCG EFI protocol and INT1A interface will not be available.
Device Select	Select the TPM device: Options: TPM 1.2 , TPM 2.0 and Auto (default) <ul style="list-style-type: none"> ▶ TPM 1.2 will restrict support to TPM 1.2 devices ▶ TPM 2.0 will restrict support to TPM 2.0 devices ▶ Auto will support both with the default set to TPM 2.0 devices if not found., TPM 1.2 device will be enumerated.

4.2.5 ACPI Settings

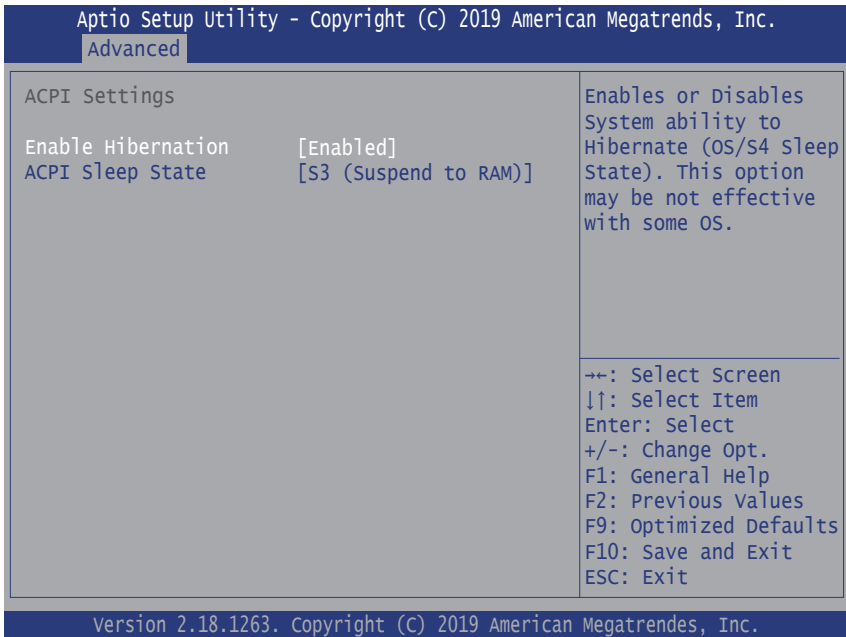

Setting	Description
Enable Hibernation	Enable (default) or Disable System ability to Hiber-nate (OS/S4 Sleep State). This option may be not effective with some OS.
ACPI Sleep State	Select the highest ACPI sleep state the system will enter when the SUSPEND button is pressed. ► Options: Suspend Disabled and S3 (Suspend to RAM) (default).

4.2.6 FAN2 Smart Settings

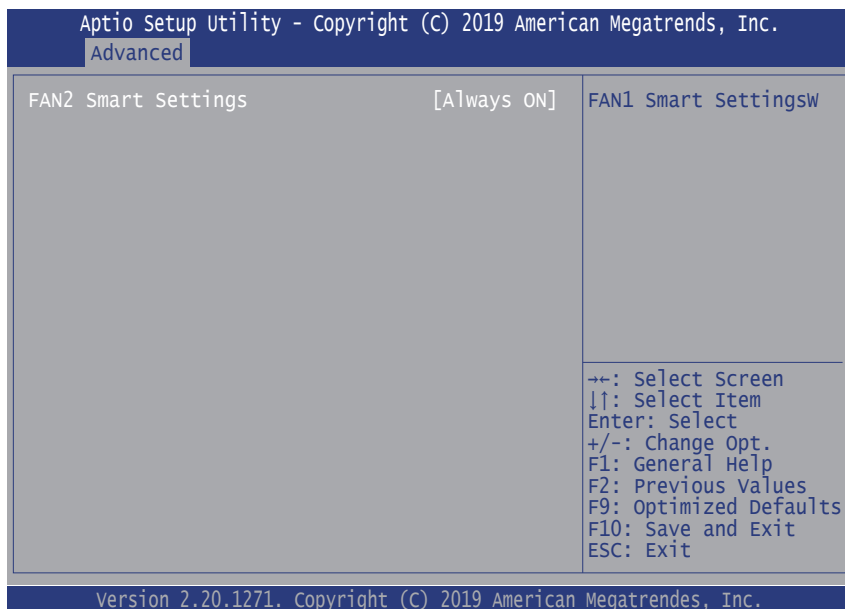

Setting	Description
FAN2 Smart Settings	Select the Smart Fan function. ► Options: Smart FAN , Always ON (default), Always OFF and None FAN .

4.2.7 PCI Subsystem Settings

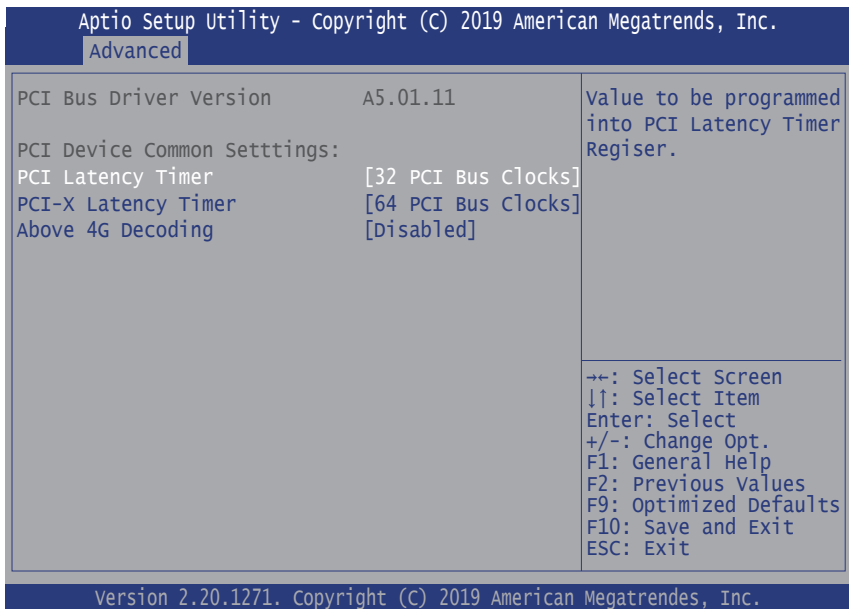

Setting	Description
PCI Latency Timer	Value to be programmed into PCI Latency timer Register. ► Default: 32 PCI Bus Clocks
PCI-X Latency Timer	Value to be programmed into PCI Latency timer Register. ► Default: 64 PCI Bus Clocks
Above 4G Decoding	Enable/Disable (default) 64bit capable Devices to be Decoded in Above 4G Address Space (Only if System Supports 64 bit PCI Decoding).

4.2.8 NVMe Configuration

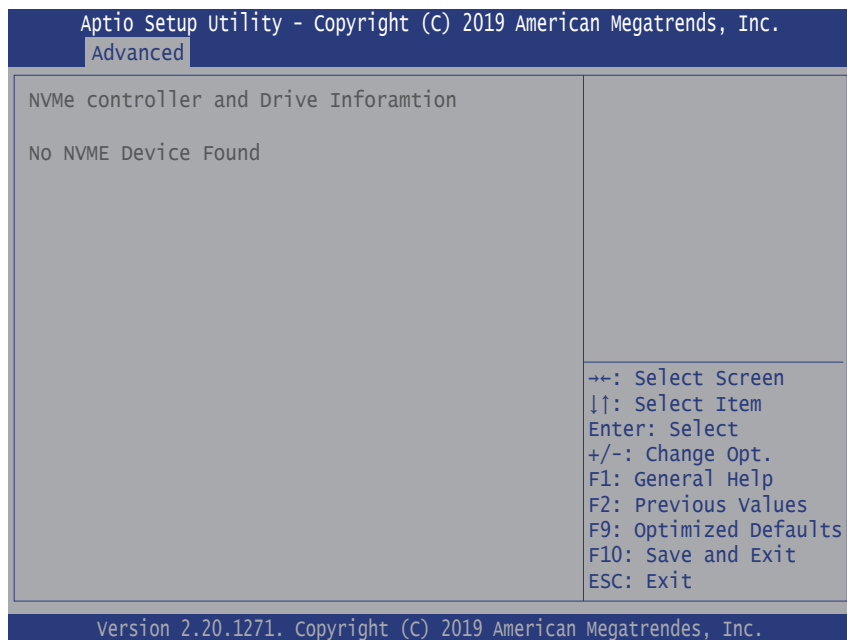

Access this submenu to view the NVMe controller and driver information.

4.2.9 USB Configuration

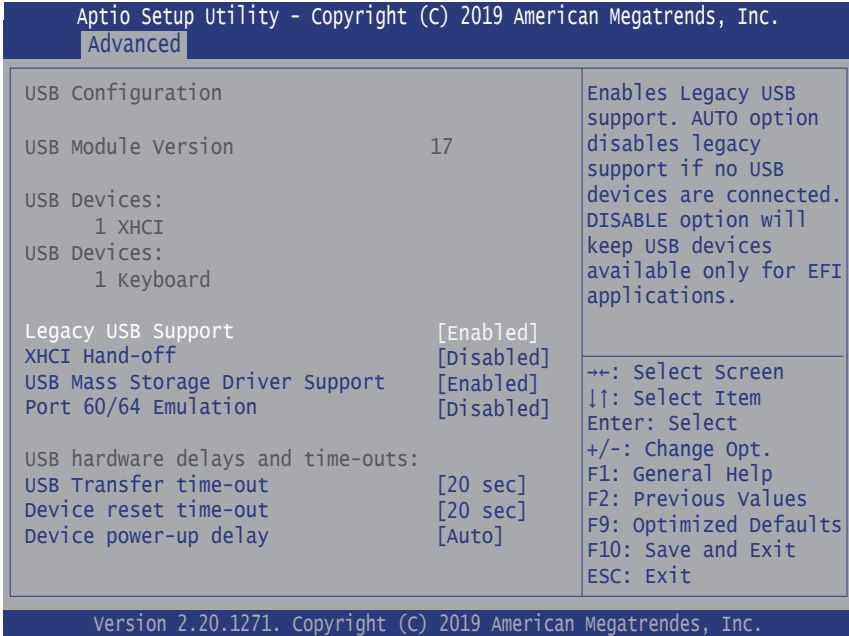

Setting	Description
Legacy USB Support	Sets legacy USB support. ► Options: Enabled (default), Disabled and Auto . AUTO option disables legacy support if no USB devices are connected. Disable option will keep USB devices available only for EFI applications.
XHCI Hand-off	Enable (default) or Disable XHCI Hand-off This is a workaround for OSes without XHCI hand-off support. The XHCI ownership change should be claimed by XHCI driver.
USB Mass Storage Driver Support	Enable (default) or Disable USB Mass Storage Driver Support.

Port 60/64 Emulation	<p>Enables/Disables (default) I/O port 60h/64h emulation support. This should be enabled for the complete USB keyboard legacy support. USB keyboard legacy support for non-USB aware OSES.</p> <p>► Options: Enabled and Disabled (default).</p>
USB hardware delay and time-out	
USB Transfer time-out	<p>Use this item to set the time-out value for control, bulk, and interrupt transfers.</p> <p>► Options available are: 1 sec, 5 sec, 10 sec, 20 sec (default)</p>
Device reset time-out	<p>Use this item to set USB mass storage device start unit command time-out.</p> <p>► Options available are: 10 sec, 20 sec (default), 30 sec, 40 sec</p>
Device power-up delay	<p>Use this item to set maximum time the device will take before it properly reports itself to the host controller.</p> <p>► Options available are:</p> <p>Auto (Default): 'Auto' uses default value: for a root port it is 100 ms, for a hub port the delay is taken from hub descriptor.</p> <p>Manual: Select Manual you can set value for the following sub-item: 'Device Power-up delay in seconds', the delay range in from 1 to 40 seconds, in one second increments.</p>

4.2.10 Hardware Monitor

The screenshot shows the 'Advanced' sub-menu of the Aptio Setup Utility. The title bar reads 'Aptio Setup Utility - Copyright (C) 2019W American Megatrends, Inc.' and the sub-menu is titled 'Advanced'. The main content area is divided into two sections. The left section, titled 'PC Health Status', lists several hardware metrics: CPU Temperature at +37°C, Fan1 Speed at N/A, VCORE at +0.858 V, VCCDU at +1.189 V, and VIN at +11.942 V. The right section lists navigation and function keys: ++ for Select Screen, ↓↑ for Select Item, Enter for Select, +/- for Change Opt., F1 for General Help, F2 for Previous Values, F9 for Optimized Defaults, F10 for Save and Exit, and ESC for Exit. A footer bar at the bottom of the window reads 'Version 2.20.1271. Copyright (C) 2019 American Megatrends, Inc.'

PC Health Status	
CPU Temperature	: +37°C
Fan1 Speed	: N/A
VCORE	: +0.858 V
VCCDU	: +1.189 V
VIN	: +11.942 V

++: Select Screen
↓↑: Select Item
Enter: Select
+/-: Change Opt.
F1: General Help
F2: Previous Values
F9: Optimized Defaults
F10: Save and Exit
ESC: Exit

Version 2.20.1271. Copyright (C) 2019 American Megatrends, Inc.

Access this submenu to monitor the hardware status.

4.2.11 Super IO Configuration

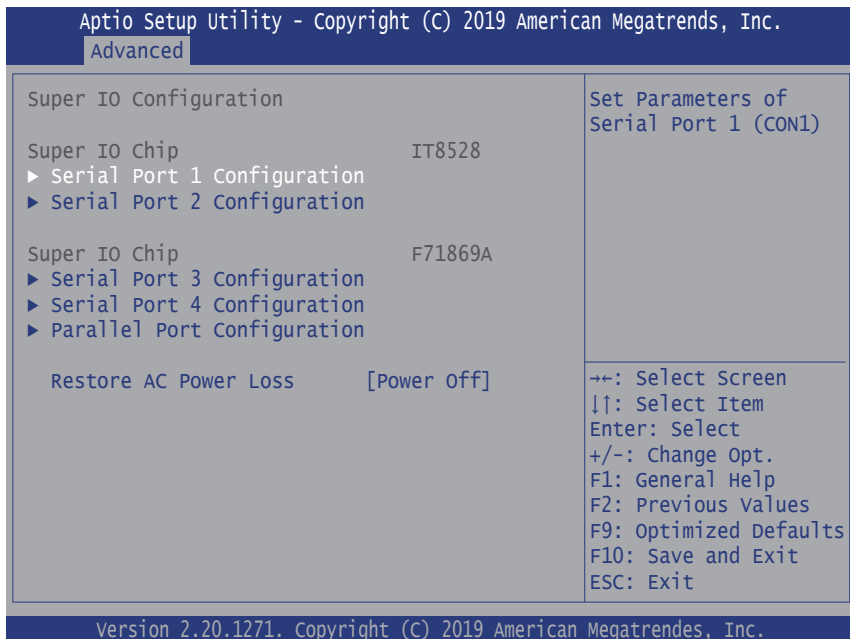

Setting	Description
Serial Port 1/2/3/4 & Parallel Port Configuration	See next page.
Restore AC Power Loss	Specify what state to go to when power is re-applied after a power failure. <ul style="list-style-type: none"> Options: Last State, Power On and Power Off (default)

Serial Port 1/2/3/4 Configuration

Setting	Description
Serial Port	Enable (default) or Disable Serial Port (COM).
Change Settings	<p>Select an optimal setting for Super IO device.</p> <ul style="list-style-type: none"> ▶ Options for Serial Port 1: <ul style="list-style-type: none"> Auto; IO=3E8h; IRQ=11 (default) ; IO=3E8h; IRQ=5, 7, 10, 11, 12; IO=2E8h; IRQ=5, 7, 10, 11, 12; ▶ Options for Serial Port 2: <ul style="list-style-type: none"> Auto IO=2E8h; IRQ=10 (default) IO=3E8h; IRQ=5, 7, 10, 11, 12; IO=2E8h; IRQ=5, 7, 10, 11, 12 ▶ Options for Serial Port 3: <ul style="list-style-type: none"> Auto IO=3F8h; IRQ=4 (default) IO=2F8h; IRQ=3, 4, 5, 7, 12; IO=3F8h; IRQ=3, 4, 5, 7, 12; ▶ Options for Serial Port 4: <ul style="list-style-type: none"> Auto IO=2F8h; IRQ=3 (default) IO=3F8h; IRQ=3, 4, 5, 7, 12; IO=2F8h; IRQ=3, 4, 5, 7, 12;

Parallel Port Configuration

Setting	Description
Parallel Port	Enable (default) or Disable Parallel Port (LPT/LPTE).
Change Settings	Select an optimal setting for Super IO device. ▶ Options: Auto IO=378h; IRQ=7 (default) IO=378h; IRQ=5, 7, 12; IO=278h; IRQ=5, 7, 12; IO=3BCh; IRQ=5, 7, 12;
Device Mode (only for Parallel Port Configuration)	Change the Printer Port mode. ▶ Options: STD Printer Mode (default) SPP Mode EPP-1.9 and SPP Mode EPP-1.7 and SPP Mode ECP Mode ECP and EPP 1.9 Mode ECP and EPP 1.7 Mode.

4.2.12 S5 RTC Wake Settings

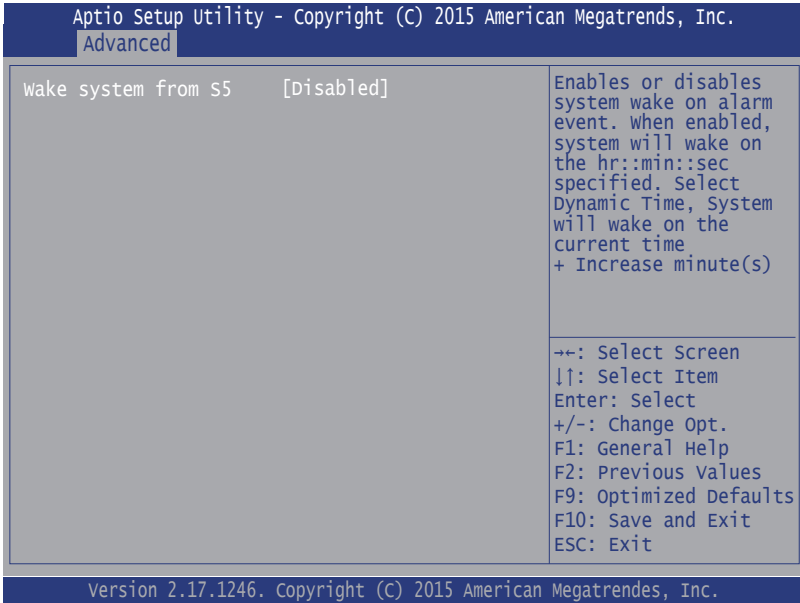

Setting	Description
Wake System from S5	<p>Enable or Disable (default) system wake on alarm event.</p> <ul style="list-style-type: none"> Options available are: <ul style="list-style-type: none"> Disabled (default): Fixed Time: System will wake on the hr::min::sec specified. DynamicTime: If selected, you need to set Wake up minute increase from 1 - 5. System will wake on the current time + increase minute(s).

4.2.13 Serial Port Console Redirection

Select this submenu to configure the serial port console redirection configuration.

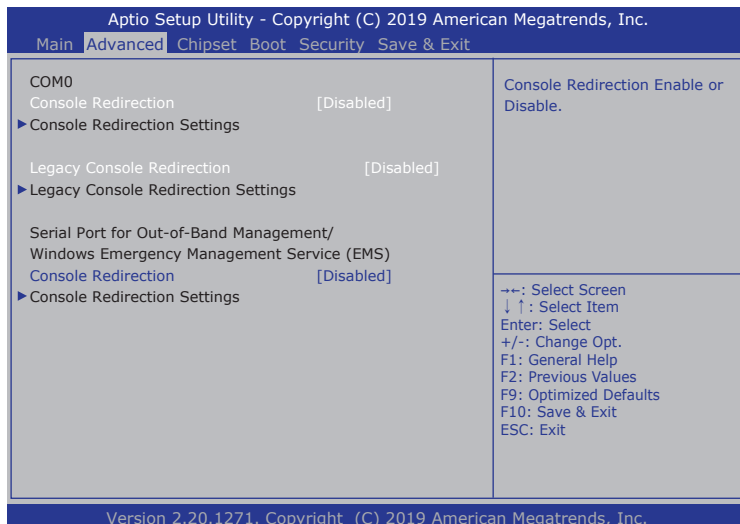

Setting	Description
Console Redirection	Enable or Disable (default) console redirection. Following submenu is available only when Console Redirection is set to Enabled .
Legacy Console Redirection Settings	
Redirection COM Port	Select a COM port to display redirectino of Legacy OS and Legacy OPROM message. ▶ COM0 is the default.
Resolution	On legacy OS, the Number of Rows and Columns supported redirection. ▶ 80x24 is the default.

Redirect After POST	<p>When Bootloader is selected, then Legacy Console Redirection is disabled before booting to legacy OS. When Always Enable is selected, then Legacy Console Redirection is enabled for legacy OS. Default settinf for this option is set to Always Enable</p> <ul style="list-style-type: none">▶ Options available are:<ul style="list-style-type: none">Always Enable(default): set the Redirection to be always activeBoot Loader: set the Redirection to be active during POST and Boot Loader
Console Redirection	<p>Enables/Disables console redirection.</p> <ul style="list-style-type: none">▶ Disabled is the default.▶ Following submenu is available only when Console Redirection is set to Enabled.

4.2.14 Network Stack Configuration

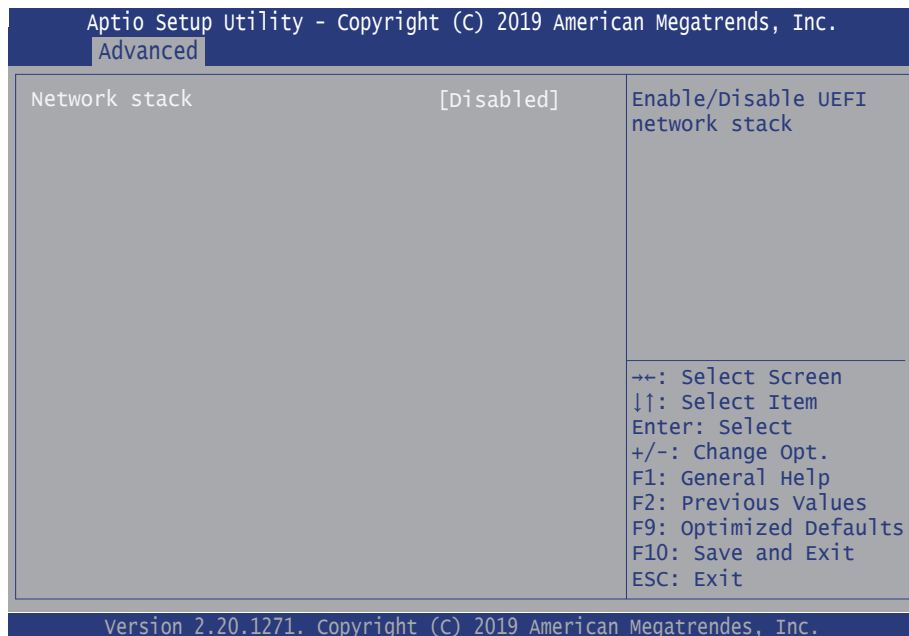

Setting	Description
Network Stack	Enables/disables (default) UEFI network stack. The following settings is available only when Network Stack is enabled.
IPv4 PXE Support	Enables (default) / disables IPv4 PXE boot Support.
IPv4 HTTP Support	Enables/disables (default) IPv4 HTTP boot Support. If disabled, IPv4 HTTP boot support will not be available.
IPv6 PXE Support	Enables/disables IPv6 PXE boot Support. ▶ Enabled is the default.
IPv6 HTTP Support	Enables/disables (default) IPv6 HTTP boot Support. If disabled, IPv6 HTTP boot support will not be available.

IPSEC Certificate	Enables (default) / disables IPSEC certificate for Ikev.
PXE boot wait time	Setup PXE boot wait time to press ESC key to about the PXE boot. Default: 0
Media detect time	Setup wait time in sec to detect media. Default: 1

4.2.15 CSM Configuration

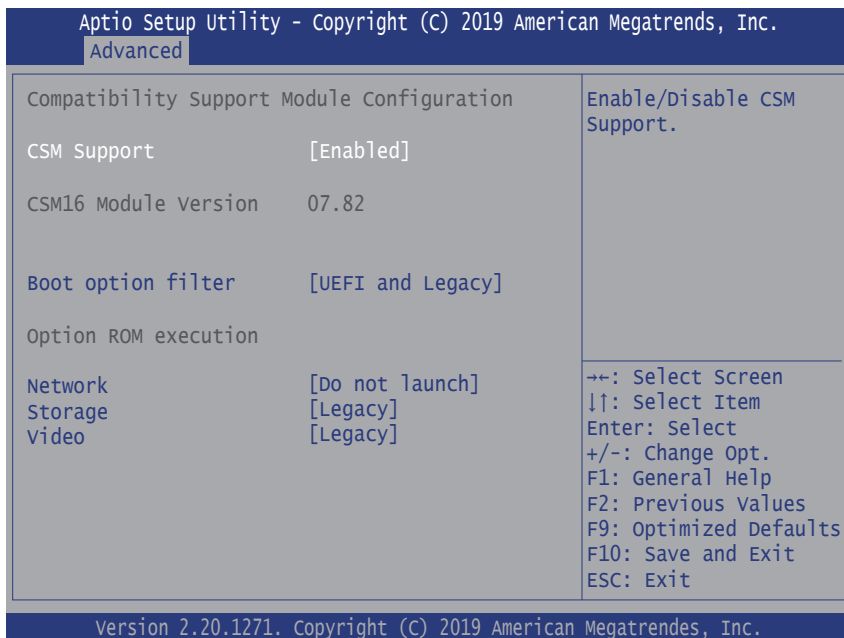

Setting	Description
CSM Support	Enable (default) or Disable CSM Support.
Boot option filter	Control the Legacy/UEFI ROMs priority. ▶ Options: UEFI and Legacy (default), Legacy only and UEFI only
Network	Control the execution of UEFI and Legacy PXE OpROM ▶ Options: Do not lauch (default), UEFI and Legacy
Storage	Control the execution of UEFI and Legacy Storage OpROM ▶ Options: Do not lauch , UEFI and Legacy (default)
Video	Control the execution of UEFI and Legacy Video OpROM ▶ Options: Do not lauch , UEFI and Legacy (default)

4.3 Chipset

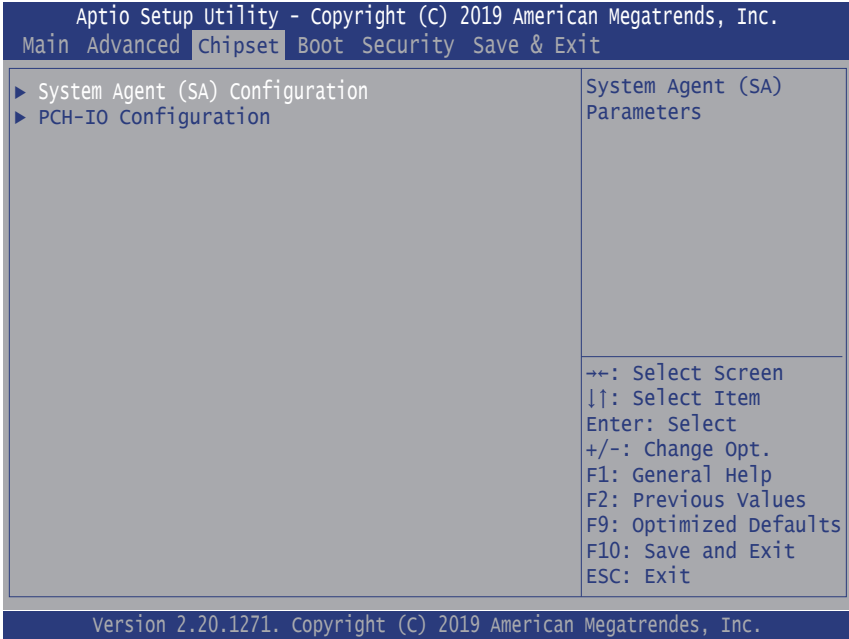

Setting	Description
System Agent (SA) Configuration	See section 4.3.1 System Agent (SA) Configuration on page 45
PCH-IO Configuration	See section 4.3.1 PCH-IO Configuration on page 47

4.3.1 System Agent (SA) Configuration

Aptio Setup Utility - Copyright (C) 2019 American Megatrends, Inc.
 Main Advanced **Chipset** Boot Security Save & Exit

System Agent (SA) Configuration		VT-d capability
SA PCIe Code Version	7.0.56.48	
VT-d	Supported	
VT-d	[Enabled]	
Above 4GB MMIO BIOS assignment	[Disabled]	
▶ Display Control		
▶ Memory Configuration		
▶ PEG Port Configuration		
		→+: Select Screen ↓↑: Select Item Enter: Select +/-: Change Opt. F1: General Help F2: Previous Values F9: Optimized Defaults F10: Save and Exit ESC: Exit

Version 2.20.1271. Copyright (C) 2019 American Megatrends, Inc.

Setting	Description
VT-d	Enable (default) or Disable VT-d function
Above 4GB MMIO BIOS assignment	Enable or Disable (default) Above 4GB MMIO BIOS assignment
Display Control	
Primary IGFX Boot Display	<p>Select the Video Device which will be activated during POST. This has no effect if external graphics present. Secondary boot display selection will appear based on your selection. VGA modes will be supported only on primary display.</p> <p>▶ Options: VBIOS Default (default), LFP, EFP2, EFP and CRT.</p>

Active LFP	Configuring LFP usage ▶ Options: No eDP (default), and eDP Port-A
Memory Configuration	Access this submenu to view the memory configuration.
PEG Port Configuration	
Enable Root Port	Enable or Disable (default) the Root Port. ▶ Options: Auto (default), Disabled and Enabled .
Max Link Speed	Configures PEG 0:1: 0 Max Speed. ▶ Options: Auto (default), Gen 1 , Gen 2 and Gen 3 .
PEG0 Slot Power Limit Value	Sets the upper limit on power supplied by slot. power limit (in Watts) is calculated by multiplying this value by the Slot power Limit Scale. ▶ Options: 0-255 , default is 75 .
PCIe Spread Spectrum Clocking	Allows to Enable (default) or Disable Spread Spectrum Clocking for compliance testing.

4.3.2 PCH-IO Configuration

Aptio Setup Utility - Copyright (C) 2019 American Megatrends, Inc.

Main Advanced **Chipset** Boot Security Save & Exit

PCH-IO Configuration

- ▶ PCI Express Configuration
- ▶ SATA Configuration
- ▶ USB Configuration
- ▶ HD Audio Configuration
- ▶ LAN Configuration

PCI Express
Configuration Settings

↔: Select Screen
 ↓↑: Select Item
 Enter: Select
 +/-: Change Opt.
 F1: General Help
 F2: Previous Values
 F9: Optimized Defaults
 F10: Save and Exit
 ESC: Exit

Version 2.20.1271. Copyright (C) 2019 American Megatrends, Inc.

Setting	Description
PCI Express Configuration	See section 4.3.2.1 PCI Express Configuration on page 48
SATA Configuration	See section 4.3.2.2 SATA Configuration on page 48
USB Configuration	See section 4.3.2.3 USB Configuration on page 49
HD Audio Configuration	See section 4.3.3 HD Audio Configuration on page 50
LAN Configuration	See section 4.3.2.4 LAN Configuration on page 50

4.3.2.1 PCI Express Configuration

Setting	Description
PCIE3/1/2 & MC1/2	Enable (default) or disable PCIE3/1/2 and MC1/2.
Topology	Identify the SATA Topology if it is default or ISATA or Flex or DirectConnect or M2. Options: Board specific, Unknown, x1, x4 (default), Sata Express and M2
ASPM Support	Disable or set the ASPM level. Force L0s will force all inks to L0s state. "Auto" will allow BIOS to auto configure."Disable" will disable ASPM. ▶ Options: Disabled (default), L0s, L1, L0sL1 and Auto .
Hot Plug	Enable or disable (default) PCI Express Hot Plug.
PCIe Speed	Select PCI Express port speed. ▶ Options: Auto (default), Gen1, Gen2 and Gen3

4.3.2.2 SATA Configuration

Setting	Description
SATA Controller` (s)	Enable (default) or disable SATA Device.
SATA Mode Selection	Determines how SATA controller(s) operate. ▶ Options: AHCI (default) and RAID
SATA Controller Speed	Indicates the maximum speed the SATA controller can support. ▶ Options: Default (default), Gen1, Gen2 and Gen3
Port 0/1/2/3	Enable or disable (default) SATA Port.
Hot Plug	Designates this port as Hot Pluggable. ▶ Options: Disabled (default), Enabled
SATA Device Type	Identify the SATA port is connected to Solid State Drive (default) or Hard Disk Drive .

4.3.2.3 USB Configuration

Setting	Description
XHCI Disable Compliance Mode	Options to disable Compliance Mode. Default is FALSE (default) to not disable Compliance Mode. Set TRUE to disable Compliance Mode.
xDCI Support	Enable/disable (default) xDCI (USB OTG Device).
USB2 PHY Sus Well power Gating	Enable/disable (default) xDCI (USB OTG Device).
USB Overcurrent	Enable (default)/ disable USB overcurrent lock. Select 'Enabled' if overcurrent functionality is used. Enabling this will make xHCI controller consume the Overcurrent mapping data.
USB Overcurrent Lock	Enable (default)/ disable USB overcurrent. Select 'Disabled' for pin-based debug. If pin-based debug is enabled but USB overcurrent is not disabled, USB DbC does not work.
USB Port Disable Override	Selectively enable/disable (default) the corresponding USB port from reporting a Device Connection to the controller.

4.3.3 HD Audio Configuration

Setting	Description
HD Audio Configuration	<p>Control Detection of the HD-Audio device.</p> <ul style="list-style-type: none"> Options available are: <ul style="list-style-type: none"> Disabled: HDA will be unconditionally disabled Enabled (default): HDA will be unconditionally Enabled

4.3.2.4 LAN Configuration

Setting	Description
PCH LAN Controller	<p>Enables/Disables onboard NIC.</p> <ul style="list-style-type: none"> Options: Enabled (default) and Disabled <p>If enabled, "Wake on LAN" option will be available to Enable (default) / Disable integrated LAN to wake the system. (the Wake On LAN cannot be disabled if ME is on at Sx state.)</p>

4.4 Security

The **Security** menu sets up the administrator password.

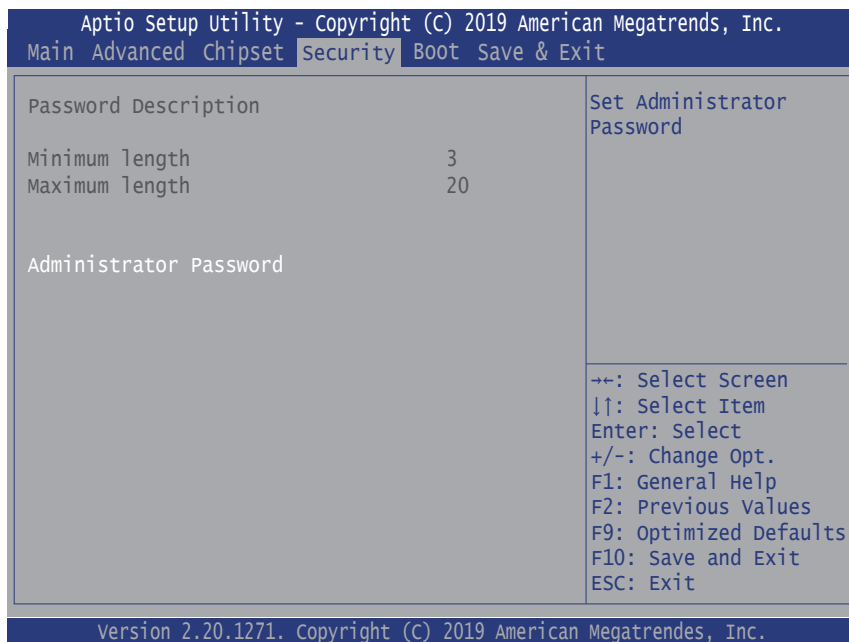

Setting	Description
Administrator Password	<p>To set up an administrator password:</p> <ol style="list-style-type: none"> 1. Select Administrator Password. The screen then pops up an Create New Password dialog. 2. Enter your desired password that is no less than 3 characters and no more than 20 characters. 3. Hit [Enter] key to submit.

4.5 Boot

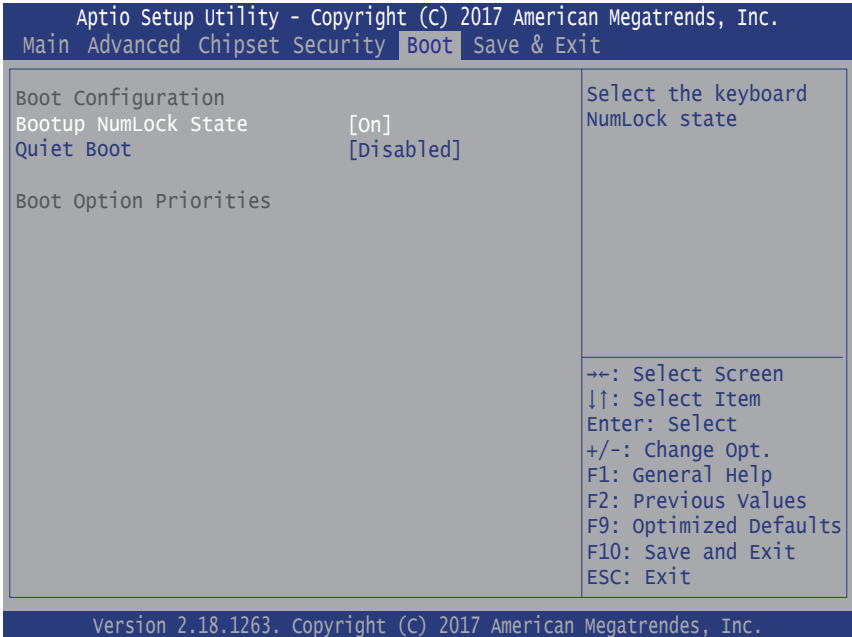

Setting	Description
Boot NumLock State	Select the keyboard NumLock state. ► Options: On and Off (default).
Fast Boot	Enable or Disable (default) boot with initialization of a minimal set of devices required to launch active boot option. Has no effect for BBS boot options.
Quiet Boot	Enable or Disable (default) Quiet Boot option.

4.6 Save & Exit

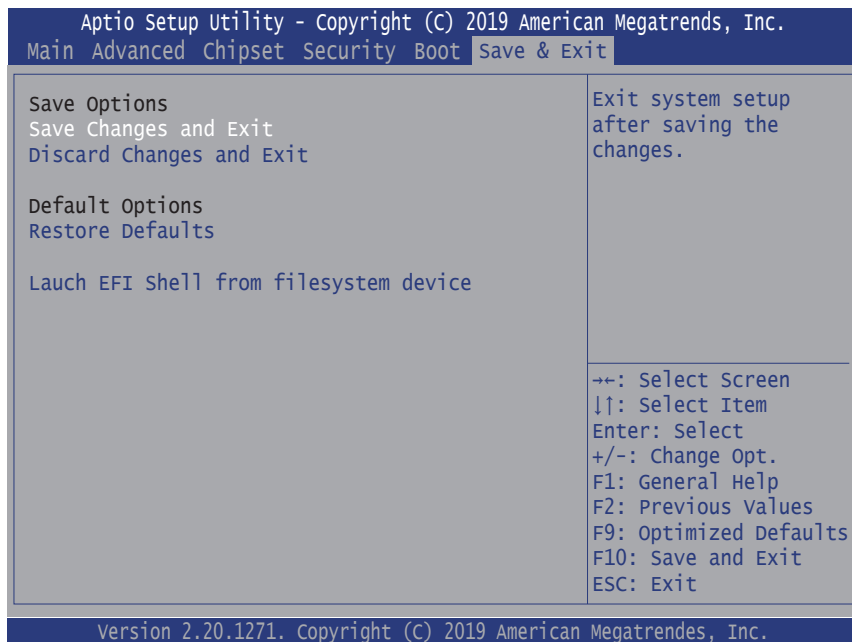

Setting	Description
Save Changes and Exit	Exit system setup after saving the changes. ► Enter the item and then a dialog box pops up: Save configuration and exit? (Yes/ No)
Discard Changes and Exit	Exit system setup without saving the changes. ► Enter the item and then a dialog box pops up: Quit without saving? (Yes/ No)
Restore Defaults	Restore/Load Default values for all the setup options. ► Enter the item and then a dialog box pops up: Load Optimized Defaults? (Yes/ No)
Launch EFI Shell from filesystem device	Attempts to launch EFI shell application (Shell.efi) from one of the available filesystem devices.

This page is intentionally left blank.



Appendix

Appendix A: I/O Port Address Map

Each peripheral device in the system is assigned a set of I/O port addresses which also becomes the identity of the device. The following table lists the I/O port addresses used.

Address	Device Description
03F8-03FF	Communications Port (COM1)
02F8-02FF	Communications Port (COM2)
03E8-03EF	Communications Port (COM3)
02E8-02EF	Communications Port (COM4)
002E-002F	Motherboard resources
004E-004F	Motherboard resources
0061-0061	Motherboard resources
0070-0071	Motherboard resources
0080-0080	Motherboard resources
0092-0092	Motherboard resources
00B2-00B3	Motherboard resources
1800-18FE	Motherboard resources
0A00-0A1F	Motherboard resources
0A20-0A2F	Motherboard resources
0A30-0A3F	Motherboard resources
0CF8-0CFF	PCI Express Configuration Access Port
0378-037F	Printer Port (LPT1)
0020-0021	Programmable interrupt controller
00A0-00A1	Programmable interrupt controller
04D0-04D1	Programmable interrupt controller
F040-F05F	SM Bus Controller
F090-F097	Standard SATA AHCI Controller
F080-F083	Standard SATA AHCI Controller
F060-F07F	Standard SATA AHCI Controller
0040-0043	System timer

Appendix B: Interrupt Request Lines (IRQ)

Peripheral devices use interrupt request lines to notify CPU for the service required. The following table shows the IRQ used by the devices on board.

Level	Function
IRQ0	System timer
IRQ1	PS/2 Keyboard
IRQ3	Communications Port (COM2)
IRQ4	Communications Port (COM1)
IRQ5	SM Bus Controller
IRQ8	System CMOS/real time clock
IRQ10	Communications Port (COM4)
IRQ11	Communications Port (COM3)
IRQ12	PS/2 Mouse
IRQ16~IRQ23	PCIe Devices

Appendix C: Watchdog Timer (WDT) Setting

WDT is widely used for industry application to monitor the activity of CPU. Application software depends on its requirement to trigger WDT with adequate timer setting. Before WDT time out, the functional normal system will reload the WDT. The WDT never time out for a normal system. The WDT will not be reloaded by an abnormal system, then WDT will time out and reset the system automatically to avoid abnormal operation.

This board supports 255 levels watchdog timer by software programming I/O ports. Below are the source codes written in C, please take them as WDT application example.

```
/*-----*/
#include <math.h>
#include <stdio.h>
#include <dos.h>

int WDTCount;

int main(void)
{
    unsigned char iCount;

    printf("WDT Times ( 1 ~ 255 ) : ");
    scanf("%d",&iCount);
    printf("\n");

    WDT_Start(iCount);

    return 0;
}

void WDT_Start(int iCount)
{
    outportb(0x66,0xBA);    /* Enable Watch Dog */
    delay(2000);

    WDTCount = iCount;
    outportb(0x62, WDTCount); /* Number is Watch Dog Down count number */
    delay(2000);

    outportb(0x62, 0x00);    /* Minute is 1 count unit by minute */
                          /* Minute is 0 count unit by second */

}

void WDT_Stop(void)
{
    outportb(0x66,0xBB);    /* Disable Watch Dog */
}

void WDT_Clear(void)
```

```
{
    outportb(0x66,0xBA);    /* Enable Watch Dog */
    delay(2000);

    outportb(0x62, WDTCnt); /* Number is Watch Dog Down count number */
    delay(2000);

    outportb(0x62, 0x00);   /* Minute is 1 count unit by minute */
                           /* Minute is 0 count unit by second */
}
```

Appendix D: DIO Sample Code

```
/*-----*/
#include "math.h"
#include "stdio.h"
#include "dos.h"

void GPIOMode(int iMode);
void GPIOData(int iData);
int GPIOStatus();

int main(void)
{
    int iInput;

    GPIOMode(0xF);
    delay(10000);

    GPIOData(0x0A);
    delay(30000);
    iInput = GPIOStatus();
    printf(" Data : %2x \n",iInput);

    GPIOData(0x05);
    delay(30000);
    iInput = GPIOStatus();
    printf(" Data : %2x \n",iInput);

    return 0;
}

void GPIOMode(int iMode)
{
    outportb(0x66,0xEB);    /* Select DIO pin to output or input */
    delay(2000);
    outportb(0x62,iMode);
}

void GPIOData(int iData)
{
    outportb(0x66,0xEA);    /* Set DIO output pin status */
    delay(2000);
    outportb(0x62,iData);
}

int GPIOStatus()
{
    int iStatus;

    outportb(0x66,0xEC);    /* Get DIO pin status */
    delay(2000);
    iStatus = inportb(0x62);

    return iStatus;
}
```